

ASME B1.20.1-2013

[Revision of ASME B1.20.1-1983 (R2006)]

# Pipe Threads, General Purpose (Inch)

---

AN AMERICAN NATIONAL STANDARD



The American Society of  
Mechanical Engineers

INTENTIONALLY LEFT BLANK

**ASME B1.20.1-2013**  
[Revision of ASME B1.20.1-1983 (R2006)]

# Pipe Threads, General Purpose (Inch)

---

**AN AMERICAN NATIONAL STANDARD**



**The American Society of  
Mechanical Engineers**

Two Park Avenue • New York, NY • 10016 USA

Date of Issuance: November 15, 2013

This Standard will be revised when the Society approves the issuance of a new edition. There will be no written interpretations of the requirements of this Standard issued to this edition.

Periodically certain actions of the ASME B1 Committee may be published as Cases. Cases are published on the ASME Web site under the Committee Pages at <http://cstools.asme.org/> as they are issued.

Errata to codes and standards may be posted on the ASME Web site under the Committee Pages to provide corrections to incorrectly published items, or to correct typographical or grammatical errors in codes and standards. Such errata shall be used on the date posted.

The Committee Pages can be found at <http://cstools.asme.org/>. There is an option available to automatically receive an e-mail notification when errata are posted to a particular code or standard. This option can be found on the appropriate Committee Page after selecting "Errata" in the "Publication Information" section.

ASME is the registered trademark of The American Society of Mechanical Engineers.

This code or standard was developed under procedures accredited as meeting the criteria for American National Standards. The Standards Committee that approved the code or standard was balanced to assure that individuals from competent and concerned interests have had an opportunity to participate. The proposed code or standard was made available for public review and comment that provides an opportunity for additional public input from industry, academia, regulatory agencies, and the public-at-large.

ASME does not "approve," "rate," or "endorse" any item, construction, proprietary device, or activity.

ASME does not take any position with respect to the validity of any patent rights asserted in connection with any items mentioned in this document, and does not undertake to insure anyone utilizing a standard against liability for infringement of any applicable letters patent, nor assumes any such liability. Users of a code or standard are expressly advised that determination of the validity of any such patent rights, and the risk of infringement of such rights, is entirely their own responsibility.

Participation by federal agency representative(s) or person(s) affiliated with industry is not to be interpreted as government or industry endorsement of this code or standard.

No part of this document may be reproduced in any form,  
in an electronic retrieval system or otherwise,  
without the prior written permission of the publisher.

The American Society of Mechanical Engineers  
Two Park Avenue, New York, NY 10016-5990

Copyright © 2013 by  
THE AMERICAN SOCIETY OF MECHANICAL ENGINEERS  
All rights reserved.  
Printed in U.S.A.

# CONTENTS

Foreword .....	iv
Committee Roster .....	v
Correspondence With the B1 Committee .....	vi
<b>1 Introduction .....</b>	<b>1</b>
<b>2 American National Standard Pipe Thread Form .....</b>	<b>2</b>
<b>3 Specification for Taper Pipe Threads, NPT .....</b>	<b>4</b>
<b>4 Specifications for Internal Straight Threads in Pipe Couplings, NPSC .....</b>	<b>13</b>
<b>5 Specifications for Railing Joint Taper Pipe Threads, NPTR .....</b>	<b>14</b>
<b>6 Specifications for Straight Pipe Threads for Mechanical Joints; NPSM, NPSL .....</b>	<b>16</b>
<b>7 Gages and Gage Tolerances for American National Standard Taper Pipe Threads, NPT .....</b>	<b>19</b>
<b>Figures</b>	
1 Root, Crest, and Flank Engagement, NPT .....	2
2 Basic Form of American National Standard Taper Pipe Thread, NPT .....	3
3 American National Standard Taper Pipe Thread Notation .....	6
4 Gaging External Taper Threads With $L_1$ Ring Gage .....	10
5 Gaging of Chamfered Threads .....	11
6 Gaging Internal Taper Threads With $L_1$ Plug Gage .....	12
7 NPT Standard Taper Pipe Thread Plug and Ring Gages .....	20
8 Suggested Form of Gage Thread .....	21
<b>Tables</b>	
1 Limits on Crest and Root Truncation of American National Standard External and Internal Taper Pipe Threads, NPT .....	5
2 Basic Dimensions of American National Standard Taper Pipe Thread, NPT .....	8
3 Tolerances on Taper, Lead, and Angle of Pipe Threads, NPT .....	10
4 Dimensions, Internal Straight Threads in Pipe Coupling, NPSC .....	14
5 Dimensions of External and Internal Taper Pipe Threads for Railing Joints, NPTR .....	15
6 Dimensions of External and Internal Straight Pipe Threads for Fixtures, NPSM .....	17
7 Dimensions, External and Internal Straight Pipe Thread for Locknut Connections, NPSL .....	18
8 Basic Dimensions of Threaded Gages for American National Standard Taper Pipe Threads, NPT .....	22
9 Working Gage Tolerances for American National Standard Taper Pipe Thread, NPT .....	23
10 Diameter Equivalent of Variation in Half Included Angle of Thread for Tools and Gages .....	25
11 Diameter Equivalent of Variation in Lead for Tools and Gages .....	26
<b>Nonmandatory Appendices</b>	
A The Turns of Engagement Method of Gaging Product Threads .....	27
B Tap Drill Sizes .....	28
C Thread Types and Corresponding Gages and Gaging .....	29



## FOREWORD

In 1973, American National Standards Committee B2, which had formerly been responsible for pipe thread standards, was absorbed by American National Standards Institute (ANSI) Standards Committee B1 and reorganized as Subcommittee 20. A complete rewrite of the B2.1-1968 standard on Pipe Threads (Except Dryseal) was undertaken. It was approved and formally designated as an American National Standard on February 4, 1983 and was reaffirmed in 2001 and 2006. The system of numbering, to include metric conversions, is as follows:

ANSI/ASME B1.20.1, Pipe Threads, General Purpose (Inch)

ASME B1.20.2M-2006, Pipe Threads, 60°, General Purpose (Metric Translation)

These standards, ANSI/ASME B1.20.1 and B1.20.2M, have product thread dimensions and gaging in the same document. Thread inspection specifies the use of  $L_1$  taper thread gages similar to B2.1-1968. In addition, emphasis was given to the requirement that all basic thread design dimensions were to be met within the specified tolerances.

This revision of ANSI/ASME B1.20.1 has both significant and subtle substantive changes to the 1983 revision. It is more explanatory for the user than the previous revision. Significant changes are as follows:

(a) An acceptability section has been added, providing a referee method in cases of dispute. This acknowledges the potentially wide but acceptable variation in the prescribed gages and gaging methods.

(b) Figures have been updated with additional information and drawn to be more visually explanatory.

(c) The Turns of Engagement method has been moved to an appendix, due to its inherent gage correlation issues. This gaging method may be used when parties agree, but it is no longer an accepted method within the Standard.

(d) Calculated data have been revised following the rounding rules of B1.30M. This provides a standardized high level of precision in calculation. Some tabulated values changed, but no changes were deemed significant enough to affect the conformance status of products or gages. These changes are generally beyond the margin of error of the required measurements. NPTR, NPSM, and NPSL thread dimensions were not recalculated as some historical methodology, necessary for computation, was not available.

(e) Guidance for tap drill sizes has been updated to reflect varying manufacturing conditions and the wider range of available drill sizes. Instead of specifying drill sizes, the Standard now refers to the tabulated basic minor diameter of the internal thread as a reference in which to base drill size choice.

(f) Added are detailed explanations on the effects of coatings on threads, as well as guidance for precoating size compensation.

(g) The gaging point of reference is moved for external threads having chamfer diameters smaller than the minor diameter at the small end. This change was made to help ensure adequate thread engagement over a wider range of product thread chamfers. This change is correspondent to the existing treatment of chamfers for internal threads.

(h) The point of reference for checking wear on working gages is changed to basic. Previously, the point of reference was the size at the time of manufacture. This change facilitates the calibration of gages when the original size at manufacture is not known and standardizes gage sizes at maximum wear.

(i) Gaging guidance for straight pipe threads has been expanded, including allowing the No-Go to enter up to three turns, mimicking ASME B1.2.

(j) The use of indicating gages has been added as a gaging method.

Following the approvals of the Standards Committee and ASME, approval for the new edition was granted by ANSI on October 15, 2013.

All requests for interpretation or suggestions for revisions should be sent to the Secretary, B1 Committee, The American Society of Mechanical Engineers, Two Park Avenue, New York, NY 10016-5990.

# ASME B1 COMMITTEE

## Standardization and Unification of Screw Threads

(The following is the roster of the Committee at the time of approval of this Standard.)

### STANDARDS COMMITTEE OFFICERS

**A. L. Barrows**, *Chair*  
**D. S. George**, *Vice Chair*  
**A. L. Guzman**, *Secretary*

### STANDARDS COMMITTEE PERSONNEL

<b>A. L. Barrows</b> , Swanson Tool Manufacturing, Inc.	<b>R. P. Knittel</b> , Leitech-U.S. Ltd.
<b>K. Bly</b> , Vermont Thread Gage	<b>M. H. McWilliams</b> , PMC Lone Star
<b>G. A. Cuccio</b> , Capitol Manufacturing Co.	<b>D. R. Maisch</b> , <i>Alternate</i> , PMC Lone Star
<b>R. Dodge</b> , Penroyer Dodge Co.	<b>D. Miskinis</b> , Kennametal, Inc.
<b>D. Everett</b> , National Institute of Standards & Technology	<b>D. R. Oas</b> , Seaway Bolt & Specials Corp.
<b>J. O. Gehret III</b> , Vermont Thread Gage, LLC	<b>J. R. Popovic</b> , Cleveland Speciality Inspection Services, Inc.
<b>D. S. George</b> , Ramco Specialties	<b>M. W. Rose</b> , Glastonbury Southern Gage
<b>J. Gervasi</b> , Kerr Lakeside, Inc.	<b>E. Schwartz</b> , Consultant
<b>J. Greenslade</b> , Industrial Fastener Institute	<b>B. F. Sheffler</b> , Dresser-Rand Co.
<b>A. L. Guzman</b> , The American Society of Mechanical Engineers	<b>D. Skierski</b> , <i>Contributing Member</i> , Sterling Gage & Calibration, LLC
<b>R. J. Hukari</b> , SPS Technologies	<b>R. D. Strong</b> , Doerken Corp.
<b>L. C. Johnson</b> , The Johnson Gage Co.	<b>A. F. Thibodeau</b> , <i>Honorary Member</i> , Swanson Tool Manufacturing, Inc.
<b>P. A. Larouche</b> , <i>Alternate</i> , The Johnson Gage Co.	<b>C. J. Wilson</b> , <i>Contributing Member</i> , Consultant
<b>D. D. Katz</b> , Precision Fittings	

### SUBCOMMITTEE 20 — PIPE THREADS

<b>D. D. Katz</b> , <i>Chair</i> , Precision Fittings	<b>X. Li</b> , <i>Contributing Member</i> , China Productivity Center for Machinery Industry
<b>P. A. Larouche</b> , <i>Vice Chair</i> , The Johnson Gage Co.	<b>D. R. Maisch</b> , PMC Lone Star
<b>K. Bly</b> , Vermont Thread Gage	<b>M. H. McWilliams</b> , PMC Lone Star
<b>M. Cox</b> , <i>Contributing Member</i> , Consultant	<b>D. R. Oas</b> , Seaway Bolt & Specials Corp.
<b>G. A. Cuccio</b> , Capitol Manufacturing Co.	<b>J. R. Popovic</b> , Cleveland Speciality Inspection Services, Inc.
<b>R. Dodge</b> , Penroyer Dodge Co.	<b>M. W. Rose</b> , Glastonbury Southern Gage
<b>J. O. Gehret III</b> , Vermont Thread Gage, LLC	<b>A. D. Shepherd</b> , Emuge Corp.
<b>J. R. Gervasi</b> , Kerr Lakeside, Inc.	<b>D. Skierski</b> , <i>Contributing Member</i> , Sterling Gage & Calibration, LLC
<b>J. A. Gruber</b> , <i>Contributing Member</i> , J. A. Gruber & Associates, LLC	<b>A. F. Thibodeau</b> , <i>Contributing Member</i> , Swanson Tool Manufacturing, Inc.
<b>L. C. Johnson</b> , The Johnson Gage Co.	
<b>R. P. Knittel</b> , Leitech-U.S. Ltd.	

## CORRESPONDENCE WITH THE B1 COMMITTEE

**General.** ASME Standards are developed and maintained with the intent to represent the consensus of concerned interests. As such, users of this Standard may interact with the Committee by requesting interpretations, proposing revisions, and attending Committee meetings. Correspondence should be addressed to:

Secretary, B1 Standards Committee  
The American Society of Mechanical Engineers  
Two Park Avenue  
New York, NY 10016-5990

**Proposing Revisions.** Revisions are made periodically to the Standard to incorporate changes that appear necessary or desirable, as demonstrated by the experience gained from the application of the Standard. Approved revisions will be published periodically.

The Committee welcomes proposals for revisions to this Standard. Such proposals should be as specific as possible, citing the paragraph number(s), the proposed wording, and a detailed description of the reasons for the proposal, including any pertinent documentation.

**Proposing a Case.** Cases may be issued for the purpose of providing alternative rules when justified, to permit early implementation of an approved revision when the need is urgent, or to provide rules not covered by existing provisions. Cases are effective immediately upon ASME approval and shall be posted on the ASME Committee Web page.

Request for Cases shall provide a Statement of Need and Background Information. The request should identify the Standard, the paragraph, figure or table number(s), and be written as a Question and Reply in the same format as existing Cases. Request for Cases should also indicate the applicable edition(s) of the Standard to which the proposed Case applies.

**Attending Committee Meetings.** The B1 Standards Committee regularly holds meetings, which are open to the public. Persons wishing to attend any meeting should contact the Secretary of the B1 Standards Committee.



# Pipe Threads, General Purpose (Inch)

## 1 INTRODUCTION

### 1.1 Scope

This Standard covers dimensions and gaging of pipe threads of the following series:

NPT  
NPSC  
NPTR  
NPSM  
NPSL

### 1.2 Related Standard

Hose coupling joints are ordinarily made with straight internal and external loose-fitting threads. There are several standards of hose threads having various diameters and pitches, one of which is based on the American National Standard Pipe Thread. By the use of this thread series, NPSH, it is possible to join small hose couplings in sizes  $\frac{1}{2}$  to 4, inclusive, to ends of standard pipe having American National Standard external pipe threads, using a gasket to seal the joint. For dimensions, tolerances, and gaging, see ASME B1.20.7.

### 1.3 Thread Designations

**1.3.1** The types of pipe threads included in this Standard are designated by specifying in sequence the nominal pipe size, number of threads per inch, and the thread series symbol as follows:

$\frac{1}{8}$ -27 NPT  
 $\frac{1}{8}$ -27 NPSC  
 $\frac{1}{2}$ -14 NPTR  
 $\frac{1}{8}$ -27 NPSM  
 $\frac{1}{8}$ -27 NPSL

Decimal equivalent notation may be substituted for fractional pipe sizes. For example

0.125-27 NPT

For left-hand threads, add "LH" to the designation. For example

$\frac{1}{8}$ -27 NPT-LH

Designations without "LH" will signify right-hand threads.

**1.3.2** Each of these letters in the symbols has significance as follows:

N = National (American) Standard

P = Pipe  
T = Taper  
S = Straight  
C = Coupling  
R = Railing Fittings  
M = Mechanical  
L = Locknut

### 1.4 Sealing (NPT and NPSC Only)

**1.4.1 Mating Threads.** Mating threads should always contact on the thread flanks. The design tolerances are such that mating crests and roots may clear, contact, or interfere (see Fig. 1). This joint may not necessarily seal, unless a sealant is used.

**1.4.2 Sealant.** Where pressure-tight, leak-free joints are required, it is intended that threads conforming to this Standard be made up wrench-tight with a sealant. To prevent galling during installation, the sealant may have lubricating properties.

**1.4.3 Tightening Torque.** Due to application-specific variables such as materials, wall thickness, operating pressures, etc., no guidance is given in this Standard regarding joint-tightening torque. However, joints should be tightened beyond the hand-tight engagement position. Advancing the joint past hand-tight creates interference between external and internal thread flanks, produces a seal (with the use of a sealant), and helps prevent loosening of the joint. Overtightening may be detrimental to the sealing function of the joint.

**1.4.4 Other Considerations.** Out-of-roundness of mating parts can negatively affect their ability to seal when made up wrench tight. The product's elasticity and ductility will also affect sealing.

**1.4.5 Pressure-Tight Threads Without Sealant.** Pipe threads designed for pressure-tight joints that may be used without sealing compounds (Dryseal Threads) are covered in ASME B1.20.3.

### 1.5 Appendices

Useful and supplementary information that is not a part of this Standard is presented in a nonmandatory appendix. Specifically, the nonmandatory appendices cover the turns of engagement method of gaging, suggested prethreading hole diameters, and an explanatory gaging matrix.

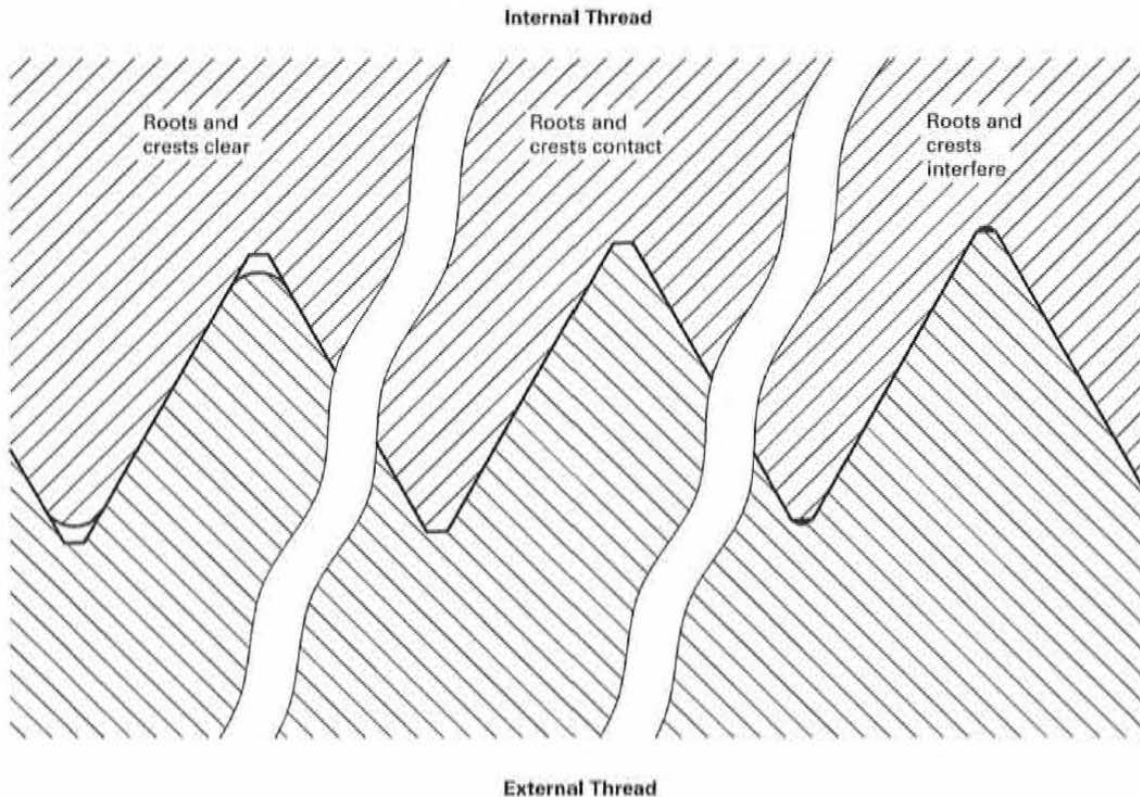
**Fig. 1 Root, Crest, and Flank Engagement, NPT**

## 1.6 Referenced Standards

The latest issues of the following documents form a part of this Standard to the extent specified herein.

ASME B1.2, Gages and Gaging for Unified Screw Threads

ASME B1.7, Screw Threads: Nomenclature, Definitions, and Letter Symbols

ASME B1.20.3, Dryseal Pipe Threads (Inch)

ASME B1.20.7, Hose Coupling Screw Threads (Inch)

ASME B1.30, Screw Threads: Standard Practice for Calculating and Rounding Dimensions

ASME B47.1, Gage Blanks

Publisher: The American Society of Mechanical Engineers (ASME), Two Park Avenue, New York, NY 10016-5990; Order Department: 22 Law Drive, P.O. Box 2900, Fairfield, NJ 07007-2900 ([www.asme.org](http://www.asme.org))

## 1.7 Terminology

Definitions of terms and symbols for thread dimensions are given in ASME B1.7.

## 2 AMERICAN NATIONAL STANDARD PIPE THREAD FORM

### 2.1 Thread Form

The form of thread profile specified in this Standard shall be known as the American National Standard Pipe Thread Form (see Fig. 2).

### 2.2 Angle of Thread

The angle between the sides of the thread is 60 deg when measured in an axial plane. The line bisecting this angle is perpendicular to the axis.

### 2.3 Thread Height

The height of the sharp  $V$  thread,  $H$ , is

$$H = 0.86602540P$$

where

$$P = \text{pitch of thread}$$



Fig. 2 Basic Form of American National Standard Taper Pipe Thread, NPT

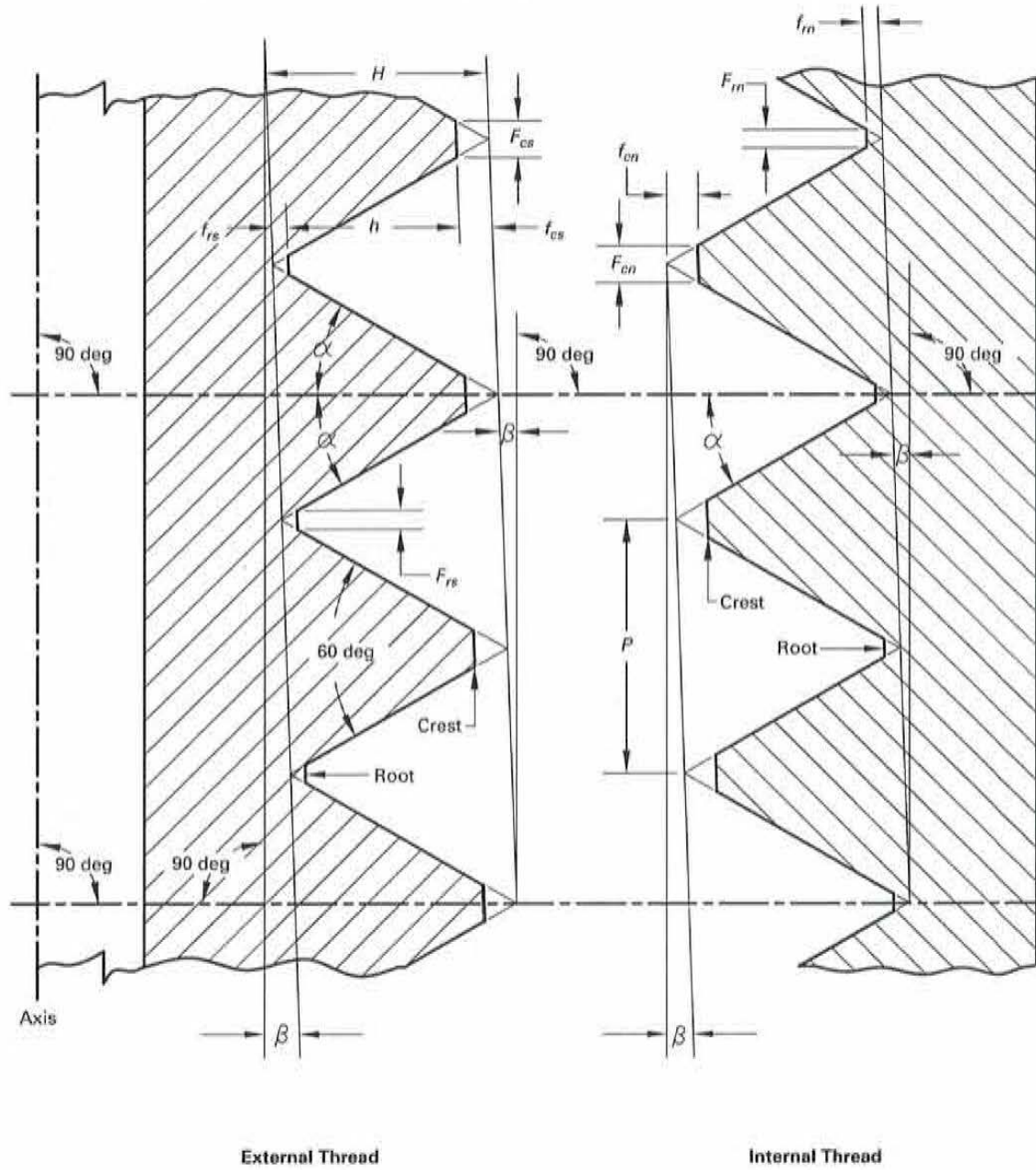

External Thread

Internal Thread

For a symmetrical straight screw thread with a 30-deg flank angle,  $H = \cot \alpha / 2n = 0.86602540P$ . For a symmetrical taper screw thread with a 30-deg flank angle and diametral taper of 0.750 in./ft,  $H = (\cot \alpha - \tan^2 \beta \tan \alpha) / 2n = 0.86574320P$ . For an 8-pitch thread, which is the coarsest standard taper pipe thread pitch, the corresponding values of  $H$  are 0.1082179 and 0.1082532, respectively. The difference of 0.000035 in. being insignificant, the value of  $H = 0.86602540P$  is used for all straight and tapered threads in this Standard.

## 2.4 Thread Truncation

The maximum height of the truncated thread,  $h$  (see Fig. 2), is based on factors entering into the manufacture of cutting tools and the making of tight joints.

$$h = 0.800P$$

The crest and root of pipe threads are truncated a minimum of  $0.033P$ . The maximum depth of truncation for the crest and root of these pipe threads will be found in Table 1. The crests and roots of the external and internal threads may be truncated either parallel to the pitch line or parallel to the axis. The illustration in Table 1, giving a sectional view of this Standard thread form, represents the truncated thread form by a straight line and sharp corners. However, a radius form is acceptable, as long as the crests and roots lie within the limits shown in Table 1. Some of the truncations in this illustration are shown with dotted lines as radii.

## 3 SPECIFICATION FOR TAPER PIPE THREADS, NPT

### 3.1 General

NPT joints made in accordance with these specifications consist of an external taper and internal taper thread (see Figs. 1 through 3). NPT taper pipe threads are intended to be made up wrench-tight and with a sealant when a pressure-tight joint is required.

**3.1.1 Notation.** The standard notation applicable to the American National Standard Taper Pipe Thread, NPT, is shown in Fig. 3.

**3.1.2 Symbols.** The following symbols are specific to this Standard:

- $D$  = outside diameter of pipe
- $E_0$  = basic pitch diameter at small end of external thread (or end of pipe)
- $E_1$  = basic pitch diameter at plane of hand-tight engagement length ( $L_1$ ), external thread, and large end of internal thread
- $E_2$  = basic pitch diameter at plane of effective thread length ( $L_2$ ), external thread
- $E_3$  = basic pitch diameter at plane of wrench-tight engagement
- $E_5$  = basic pitch diameter pipe at  $L_5$ , plane of complete thread length

- $K_0$  = basic minor diameter at small end of external thread (or end of pipe)
- $L_1$  = length of hand-tight engagement between internal and external threads
- $L_2$  = length of effective thread, external thread. Equal to  $L_1$  plus wrench make-up threads
- $L_3$  = length of thread beyond  $L_1$  allowing wrench-tight engagement, internal thread (also, wrench make-up)
- $L_4$  = overall length of thread, including vanish thread, external thread
- $L_5$  = length of complete threads, external thread, where cone of major diameter intersects outside diameter of pipe
- $V$  = length of vanish threads

**3.1.3 Handling Considerations.** The potential effects on thread form and gaging must be considered when choosing coatings and other processes. Some processes, such as barrel coating, can be damaging to the thread form, especially the crests of external threads. See para. 3.2.3 on gaging nicked threads.

**3.1.4 Form of Thread.** The form of the thread is specified in para. 2.1.

**3.1.5 Taper of Thread.** The basic taper of the thread is 1 in 16 or 0.75 in./ft measured diametrically relative to the axis.

**3.1.6 Pitch Diameters of Thread.** The basic pitch diameters of the tapered thread are determined by the following formulas based on the outside diameter of the pipe and the pitch of the thread:

$$\begin{aligned} E_0 &= D - (0.05D + 1.1) 1/n \\ &= D - (0.05D + 1.1)P \\ E_1 &= E_0 + 0.0625 L_1 \end{aligned}$$

where

- $D$  = outside diameter of pipe
- $E_0$  = pitch diameter of thread at end of pipe or small end of external thread
- $E_1$  = pitch diameter of thread at the large end of internal thread
- $L_1$  = hand-tight length of engagement between external and internal threads, also the hand-tight length of thread for both internal and external threads
- $n$  = threads per inch

**3.1.7 Length of Effective Thread.** The basic length of the effective external taper thread  $L_2$ , is determined by the following formula based on the outside diameter of the pipe and the pitch of the thread:

$$\begin{aligned} L_2 &= (0.80D + 6.8)1/n \\ &= (0.80D + 6.8)P \end{aligned}$$

where

- $D$  = outside diameter of pipe
- $n$  = threads per inch



**Table 1 Limits on Crest and Root Truncation of American National Standard External and Internal Taper Pipe Threads, NPT**

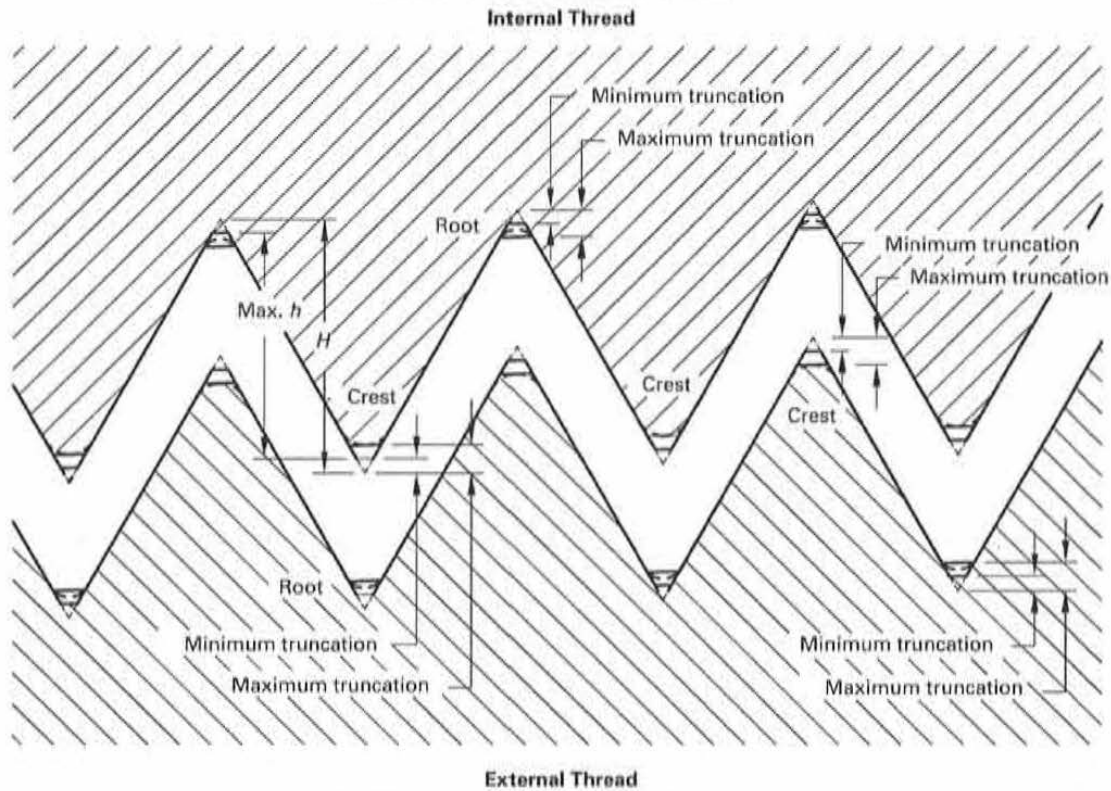

Threads/ Inch, <i>n</i>	Height of Sharp V Thread, <i>H</i>	Height of Thread, <i>h</i>		Truncation, <i>f</i>					Equivalent Width of Flat, <i>F</i>				
		Min.	Max.	Min.		Max.		Tolerance	Min.		Max.		Tolerance
				Formula	in.	Formula	in.		Formula	in.	Formula	in.	
1	2	3	4	5	6	7	8	9	10	11	12	13	14
27	0.0320750	0.02496	0.02963	0.033 <i>P</i>	0.0012	0.096 <i>P</i>	0.0036	0.0024	0.038 <i>P</i>	0.0014	0.111 <i>P</i>	0.0041	0.0027
18	0.0481125	0.03833	0.04444	0.033 <i>P</i>	0.0018	0.088 <i>P</i>	0.0049	0.0031	0.038 <i>P</i>	0.0021	0.102 <i>P</i>	0.0057	0.0036
14	0.0618590	0.05072	0.05714	0.033 <i>P</i>	0.0024	0.078 <i>P</i>	0.0056	0.0032	0.038 <i>P</i>	0.0027	0.090 <i>P</i>	0.0064	0.0037
11.5	0.0753066	0.06261	0.06957	0.033 <i>P</i>	0.0029	0.073 <i>P</i>	0.0063	0.0034	0.038 <i>P</i>	0.0033	0.084 <i>P</i>	0.0073	0.0040
8	0.1082532	0.09275	0.100	0.033 <i>P</i>	0.0041	0.062 <i>P</i>	0.0078	0.0037	0.038 <i>P</i>	0.0048	0.072 <i>P</i>	0.0090	0.0042

GENERAL NOTE: The basic dimensions of the American National Standard Taper Pipe Thread are given in inches to four or five decimal places. While this implies a greater degree of precision than is ordinarily attained, these dimensions are the basis of gage dimensions and are so expressed for the purpose of eliminating errors in computations.

Fig. 3 American National Standard Taper Pipe Thread Notation

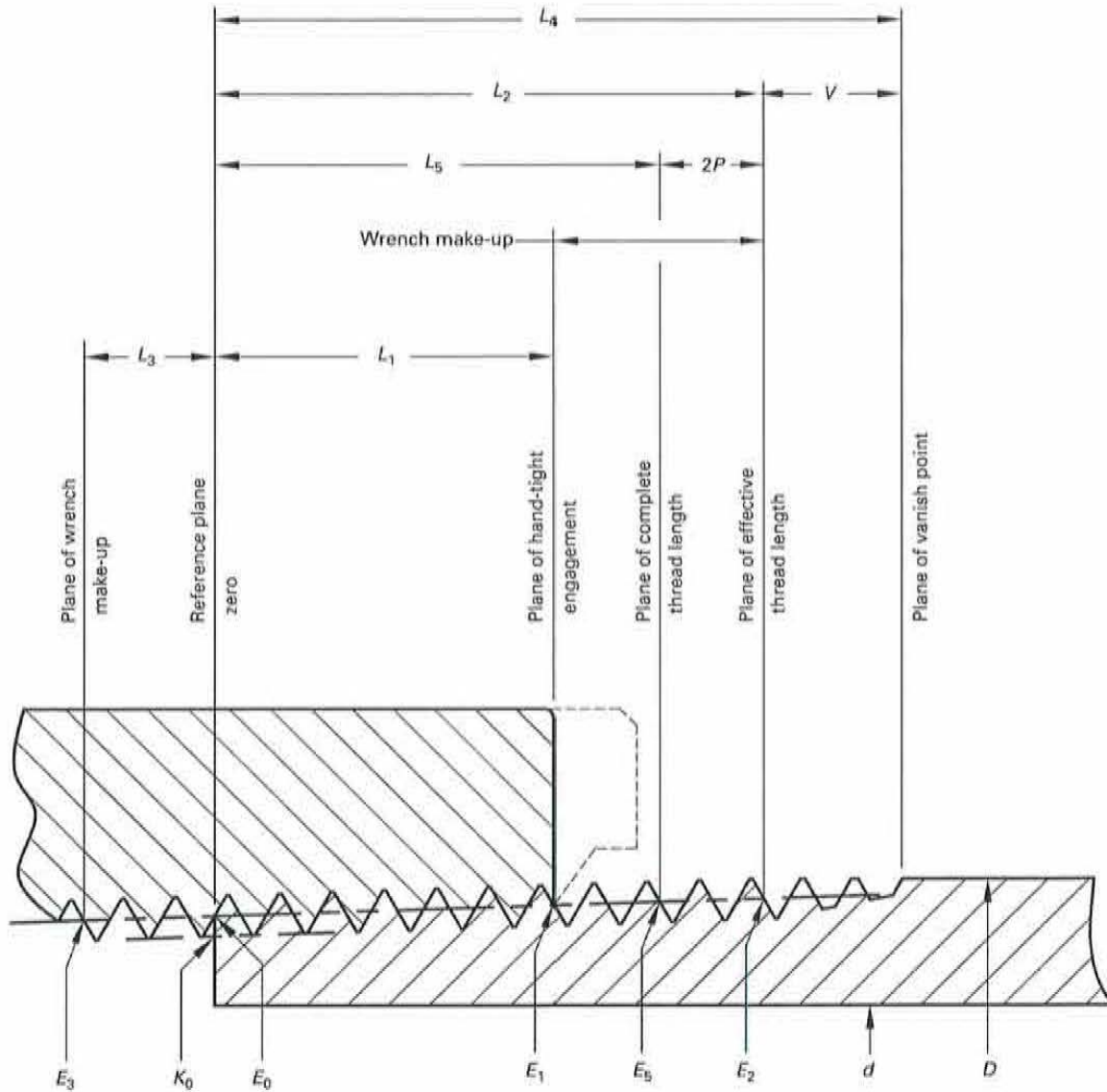



This formula determines the length of effective external thread. This may include two usable threads incomplete at the crest.

**3.1.8 Hand-Tight Engagement Between External and Internal Taper Threads.** The basic length of engagement between external and internal taper threads when screwed together hand-tight is  $L_1$ , shown in column 6, Table 2.

**3.1.9 Wrench-Tight Engagement Between External and Internal Taper Threads.** The external thread length,  $L_2 - L_1$ , and the internal thread length,  $L_3$ , are allowances for wrench-tight assembly after the hand-tight engagement of  $L_1$  lengths.

**3.1.9.1 Thread Engagement Considerations.** The gaging tolerance of  $\pm 1$  turn for both external and internal threads has the effect of potentially increasing the length of engagement by up to two turns or reducing the length of engagement by up to two turns. Working gage wear has the additional effect of reducing thread engagement by the amount gages wear past basic.

**3.1.9.2 Special Applications.** It is recognized that in special applications, such as flanges for high-pressure work, longer thread engagement is needed, in which case the pitch diameter (dimension  $E_1$ , Table 2) is maintained and the pitch diameter  $E_0$  at the end of the pipe is made smaller. The taper must be kept at  $\frac{3}{4}$  in./ft, and thread is made longer.

**3.1.10 Tolerances on Product Taper, Lead, and Angle.** The permissible variations in taper, lead, and angle are given in Table 3. This table is a guide for establishing limits of the thread elements of threading tools. The correct manufacture of tools and the use of gages should provide adequate control of functional size.

**3.1.11 Basic Dimensions.** The basic dimensions of taper pipe threads, derived from the above specifications, are given in Table 2.

## 3.2 Gaging NPT Threads

The  $L_1$  gages prescribed in this Standard are considered functional in that they give assurance of assemblability over the  $L_1$  length, the length of hand-tight engagement. They simulate a mating product thread that conforms to this Standard. They encompass multiple elements of the thread, including thread diameters, flank angle, lead, taper, and root truncation. The simultaneous engagement of all elements results in a measurement that reflects the cumulative variation of all those elements, the functional diameter. This is expressed as standoff for rings and plugs or measured directly by indicating gages. See section 7 for gage specifications.

### 3.2.1 External Thread Gaging

**3.2.1.1  $L_1$  Ring Gage.** The  $L_1$  ring and external product thread are screwed together hand-tight, and the

position relative to the small end of the ring (or basic step on a stepped ring gage) is noted (see Figs. 4 and 5). This is the standoff. The tolerance for the standoff is  $\pm 1$  turn (or  $\pm 1$  pitch, as shown in column 4 of Table 2) from the small end of the ring (or basic step on a stepped ring).

**3.2.1.2 External  $L_1$ -Indicating Gage.** The external  $L_1$ -indicating gage is set with a master plug gage, which is made to basic dimensions. Accordingly, when the product is engaged by an indicating gage, readings indicate the diametral variation from basic. The tolerance from basic is the diametral equivalent to  $\pm 1$  pitch (or  $\pm 0.0625/n$ , as shown in column 23 of Table 2).

### 3.2.2 Internal Thread Gaging

**3.2.2.1  $L_1$  Plug Gage.** The  $L_1$  plug gage and internal product thread are screwed together hand-tight, and the position relative to the basic step of the gage is noted (see Figs. 5 and 6). This is the standoff. The tolerance for the standoff is  $\pm 1$  turn (or  $\pm 1$  pitch, as shown in column 4 of Table 2) from the basic step of the plug gage.

**3.2.2.2 Internal  $L_1$ -Indicating Gage.** The internal  $L_1$ -indicating gage is set with a master ring gage, which is made to basic dimensions. Accordingly, when the product is engaged by an indicating gage, readings indicate the diametral variation from basic. The tolerance from basic is the diametral equivalent to  $\pm 1$  pitch (or  $\pm 0.0625/n$ , as shown in column 23 of Table 2).

**3.2.3 Nicked Threads.** Pipe threads are particularly susceptible to damage that interferes with proper gaging. Generally, this damage appears as "nicks" on the crest of external or internal threads. These nicks will always hold the gage back from properly seating. This makes the external functional size seem larger than it is and the internal functional size seem smaller than it is. Because pipe threads are designed to be installed wrench-tight, and the wrenching reforms the nicks to their proper crest position, some degree of nicking is acceptable. A product mated with a gage may be "rapped" and hand-tightened while engaged. Care should be exercised when rapping to minimize the potential damage to the gage. Rapping and tightening may continue until the product and gage do not engage any further. Products that remain beyond the gaging tolerance after rapping and hand-tightening are nonconforming.

**3.2.4 Treatment of Chamfers, Recesses, Counterbores.** Threaded products have thread chamfers to avoid sharp edges, protect the start thread, and aid in assembly. The nature of threads generally necessitates external chamfer diameters at least as small as the minor diameter and internal chamfer diameters at least as large as the major diameter, if complete sharp edge removal is desired. In practice, many product thread chamfers exceed the minimal chamfer that removes the

Table 2 Basic Dimensions of American National Standard Taper Pipe Thread, NPT

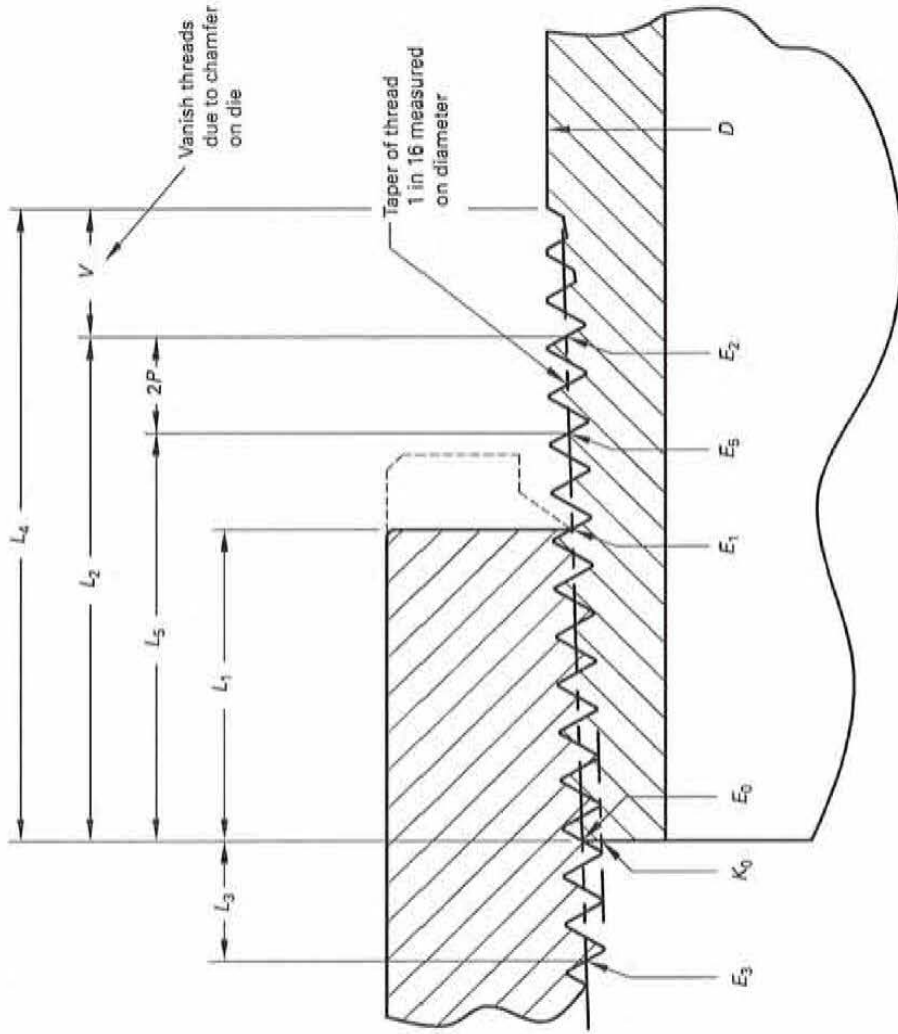



Table 2 Basic Dimensions of American National Standard Taper Pipe Thread, NPT (Cont'd)

Nominal Pipe Size	O.D. of Pipe, D	Threads/inch, n	Pitch Diameter at Beginning of External Thread, E <sub>1</sub>	Hand-tight Engagement		Effective Thread, External		Length, L <sub>1</sub> Plane to L <sub>1</sub> Plane, External Thread, L <sub>1</sub> - L <sub>2</sub>		Wrench Make-Up Length, Internal Thread		Overall Length, External Thread, L <sub>1</sub>		Nominal Complete External Threads <sup>1</sup>		Change in Diameter per Turn of Thread, 0.0625/in	Basic Minor Diameter at End of Pipe, K <sub>1</sub>						
				Length, L <sub>1</sub>	Pitch Diameter, E <sub>1</sub>	Length, L <sub>2</sub>	Pitch Diameter, E <sub>2</sub>	Length, L <sub>1</sub>	Pitch Diameter, E <sub>1</sub>	Length, L <sub>1</sub>	Pitch Diameter, E <sub>1</sub>	Length, L <sub>1</sub>	Pitch Diameter, E <sub>1</sub>	Length, L <sub>1</sub>	Pitch Diameter, E <sub>1</sub>								
1	2	3	4	5	6	7	8	9	10	11	12	13	14	15	16	17	18	19	20	21	22	23	24
1/8	0.3125	27	0.03703704	0.27118	0.1600	4.32	0.26118	0.2611	7.05	0.28750	0.1011	2.73	0.1111	3	0.26424	0.1285	3.47	0.3896	0.1870	0.28287	0.02963	0.00231	0.2415
1/8	0.4050	27	0.03703704	0.36351	0.1615	4.36	0.37360	0.2639	7.13	0.38000	0.1024	2.76	0.1111	3	0.35656	0.1285	3.47	0.3924	0.1898	0.37537	0.02963	0.00231	0.3338
1/4	0.5400	18	0.05555556	0.47739	0.2278	4.10	0.49163	0.4018	7.23	0.50250	0.1740	3.13	0.1667	3	0.46697	0.1928	3.47	0.5946	0.2907	0.49556	0.04444	0.00347	0.4329
1/4	0.6750	18	0.05555556	0.61201	0.2400	4.32	0.62701	0.4078	7.34	0.63750	0.1678	3.02	0.1667	3	0.60160	0.1928	3.47	0.6006	0.2967	0.63056	0.04444	0.00347	0.5675
1/2	0.8400	14	0.07142857	0.75843	0.3200	4.48	0.77918	0.5337	7.47	0.79178	0.2137	2.99	0.2143	3	0.74504	0.2479	3.47	0.7815	0.3909	0.78286	0.05714	0.00446	0.7014
3/4	1.0500	14	0.07142857	0.96768	0.3390	4.75	0.98687	0.5457	7.64	1.00178	0.2067	2.89	0.2143	3	0.95429	0.2479	3.47	0.7935	0.4029	0.99286	0.05714	0.00446	0.9106
1	1.3150	11.5	0.08695652	1.21363	0.4000	4.60	1.23663	0.6828	7.85	1.25631	0.2828	3.25	0.2609	3	1.19723	0.3017	3.47	0.9845	0.5089	1.24544	0.06957	0.00543	1.1441
1 1/4	1.6600	11.5	0.08695652	1.55713	0.4200	4.83	1.58338	0.7068	8.13	1.60131	0.3868	3.30	0.2609	3	1.54083	0.3017	3.47	1.0085	0.5329	1.59044	0.06957	0.00543	1.4876
1 1/2	1.9900	11.5	0.08695652	1.79609	0.4200	4.83	1.82234	0.7235	8.32	1.84131	0.3035	3.49	0.2609	3	1.77978	0.3017	3.47	1.0252	0.5496	1.83044	0.06957	0.00543	1.7266
2	2.3750	11.5	0.08695652	2.26902	0.4360	5.01	2.29627	0.7565	8.70	2.31630	0.3205	3.69	0.2609	3	2.25272	0.3017	3.47	1.0582	0.5826	2.30543	0.06957	0.00543	2.1995
2 1/2	2.8750	8	0.12500000	2.71953	0.6820	5.46	2.76216	1.1375	9.10	2.79063	0.4555	3.64	0.2500	2	2.70391	0.4338	3.47	1.5712	0.8875	2.77500	0.10000	0.00781	2.6195
3	3.5000	8	0.12500000	3.34063	0.7660	6.13	3.38850	1.2000	9.60	3.41563	0.4340	3.47	0.2500	2	3.32500	0.4338	3.47	1.6337	0.9500	3.40000	0.10000	0.00781	3.2406
3 1/2	4.0000	8	0.12500000	3.83750	0.8210	6.57	3.88681	1.2500	10.00	3.91563	0.4290	3.43	0.2500	2	3.82188	0.4338	3.47	1.6837	1.0000	3.90000	0.10000	0.00781	3.7374
4	4.5000	8	0.12500000	4.33438	0.8440	6.75	4.38713	1.3000	10.40	4.41563	0.4560	3.65	0.2500	2	4.31875	0.4338	3.47	1.7337	1.0500	4.40000	0.10000	0.00781	4.2343
5	5.5630	8	0.12500000	5.39073	0.9370	7.50	5.44929	1.4063	11.25	5.47863	0.4693	3.75	0.2500	2	5.37511	0.4338	3.47	1.8400	1.1563	5.46300	0.10000	0.00781	5.2907
6	6.6250	8	0.12500000	6.44609	0.9580	7.66	6.50397	1.5125	12.10	6.54063	0.5545	4.44	0.2500	2	6.43047	0.4338	3.47	1.9462	1.2625	6.52500	0.10000	0.00781	6.3460
8	8.6250	8	0.12500000	8.43359	1.0630	8.50	8.50003	1.7125	13.70	8.54063	0.6495	5.20	0.2500	2	8.41797	0.4338	3.47	2.1462	1.4625	8.52500	0.10000	0.00781	8.3335
10	10.7500	8	0.12500000	10.54531	1.2100	9.68	10.62094	1.9250	15.40	10.66563	0.7150	5.72	0.2500	2	10.52969	0.4338	3.47	2.3587	1.6750	10.65000	0.10000	0.00781	10.4453
12	12.7500	8	0.12500000	12.53281	1.3800	10.88	12.61781	2.1250	17.00	12.66563	0.7650	6.12	0.2500	2	12.51719	0.4338	3.47	2.5587	1.8750	12.65000	0.10000	0.00781	12.4328
14	14.0000	8	0.12500000	13.77500	1.5620	12.50	13.87263	2.2500	18.00	13.91563	0.6880	5.50	0.2500	2	13.75938	0.4338	3.47	2.6837	2.0000	13.90000	0.10000	0.00781	13.6749
16	16.0000	8	0.12500000	15.76250	1.8120	14.50	15.87375	2.4500	19.60	15.91563	0.6380	5.10	0.2500	2	15.74688	0.4338	3.47	2.8837	2.2000	15.90000	0.10000	0.00781	15.6624
18	18.0000	8	0.12500000	17.75000	2.0000	16.00	17.87500	2.6500	21.20	17.91563	0.6500	5.20	0.2500	2	17.73438	0.4338	3.47	3.0837	2.4000	17.90000	0.10000	0.00781	17.6499
20	20.0000	8	0.12500000	19.73750	2.1250	17.00	19.87031	2.8500	22.80	19.91563	0.7250	5.80	0.2500	2	19.72188	0.4338	3.47	3.2837	2.6000	19.90000	0.10000	0.00781	19.6374
24	24.0000	8	0.12500000	23.71250	2.3750	19.00	23.86094	3.1500	26.00	23.91563	0.8750	7.00	0.2500	2	23.69688	0.4338	3.47	3.6837	3.0000	23.90000	0.10000	0.00781	23.6124

GENERAL NOTE: The basic dimensions of the American National Standard Taper Pipe Thread are given in inches to four or five decimal places. While this implies a greater degree of precision than is ordinarily attained, these dimensions are the basis of gage dimensions and are so expressed for the purpose of eliminating errors in computations.

- NOTES:
- (1) Also length of L<sub>2</sub> ring gage and length from gaging notch to small end of L<sub>1</sub> plug gage.
  - (2) Also pitch diameter at gaging notch of L<sub>1</sub> plug gage (hand-tight plane).
  - (3) Also threaded length of L<sub>1</sub> plug gage.
  - (4) Reference dimension.
  - (5) The length L<sub>3</sub> from the end of the pipe determines the plane beyond which the thread form is incomplete at the crest. The next two threads are complete at the root. At this plane, the cone formed by the crests of the thread intersects the cylinder forming the external surface of the pipe (L<sub>3</sub> = L<sub>2</sub> - 2P).
  - (6) Given as information for use in selecting tap drills (see Nonmandatory Appendix B).

**Table 3 Tolerances on Taper, Lead, and Angle of Pipe Threads, NPT**

Nominal Pipe Size	Threads/ Inch, $n$	Tolerances			
		Taper on Pitch Line, $\frac{3}{4}$ in./ft		Lead in Effective Length of Threads	60-deg Angle of Threads, Deg
		Max.	Min.		
1	2	3	4	5	6
$\frac{1}{16}, \frac{1}{8}$	27	$+\frac{1}{8}$	$-\frac{1}{16}$	$\pm 0.003$	$\pm 2\frac{1}{2}$
$\frac{1}{4}, \frac{3}{8}$	18	$+\frac{1}{8}$	$-\frac{1}{16}$	$\pm 0.003$	$\pm 2$
$\frac{1}{2}, \frac{3}{4}$	14	$+\frac{1}{8}$	$-\frac{1}{16}$	$\pm 0.003$	$\pm 2$
1, $1\frac{1}{4}$ , $1\frac{1}{2}$ , 2	11.5	$+\frac{1}{8}$	$-\frac{1}{16}$	$\pm 0.003$	$\pm 1\frac{1}{2}$
$2\frac{1}{2}$ and larger	8	$+\frac{1}{8}$	$-\frac{1}{16}$	$\pm 0.003$ [Note (1)]	$\pm 1\frac{1}{2}$

**NOTE:**(1) The tolerance on lead shall be  $\pm 0.003$  in./in. on any size threaded to an effective thread length greater than 1 in.**Fig. 4 Gaging External Taper Threads With  $L_1$  Ring Gage**

Fig. 5 Gaging of Chamfered Threads



GENERAL NOTE: See para. 3.2.4.

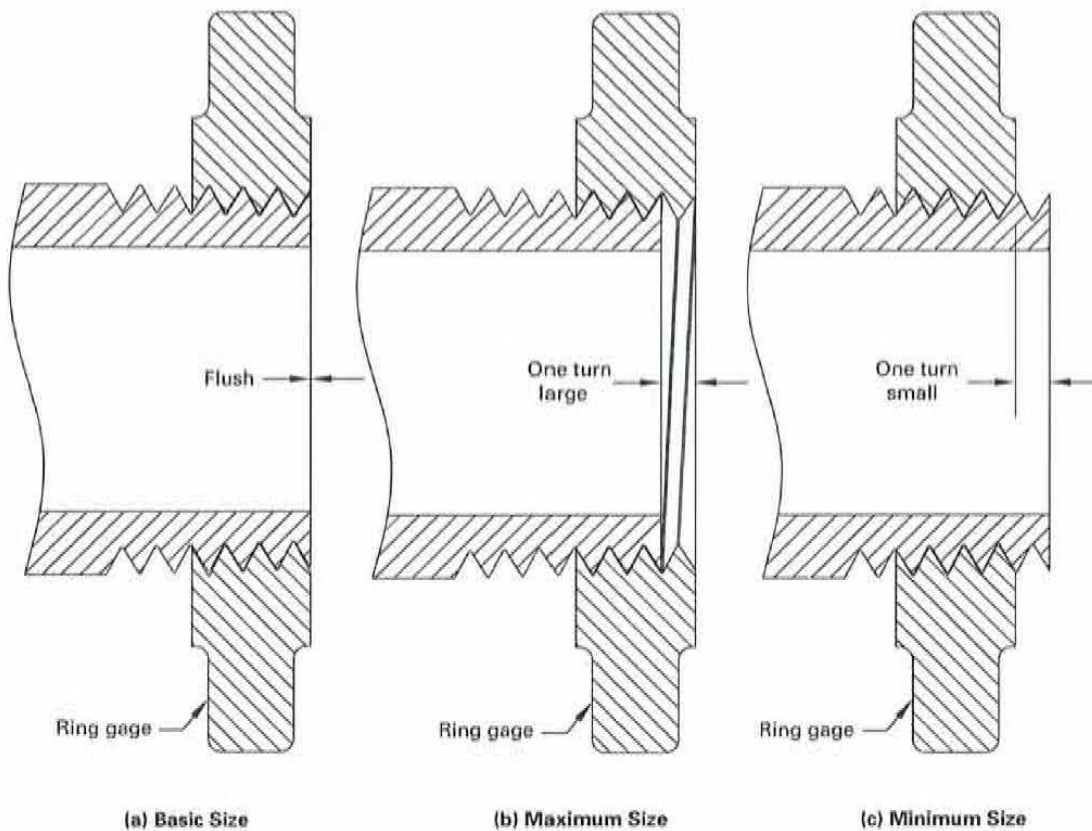
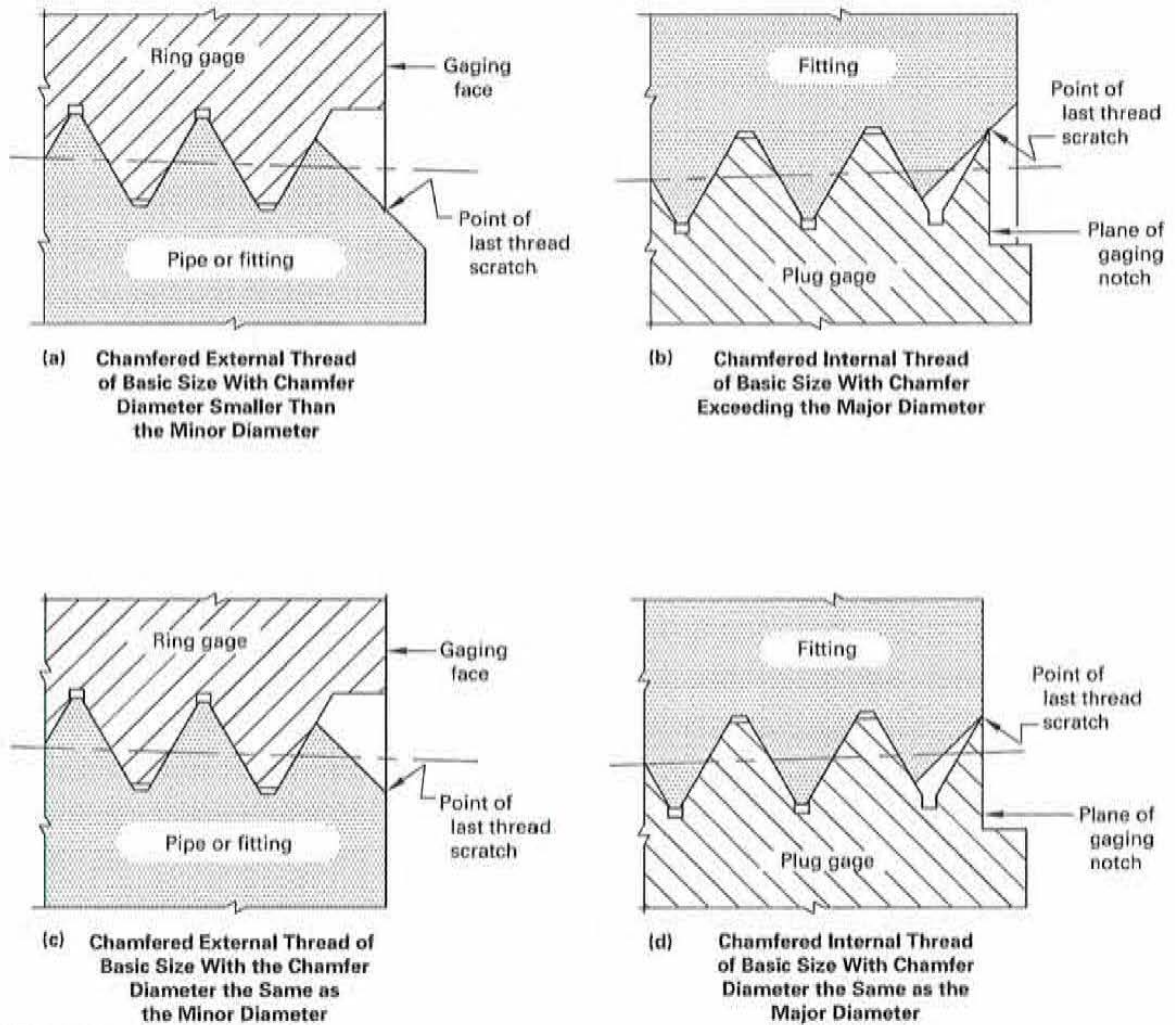
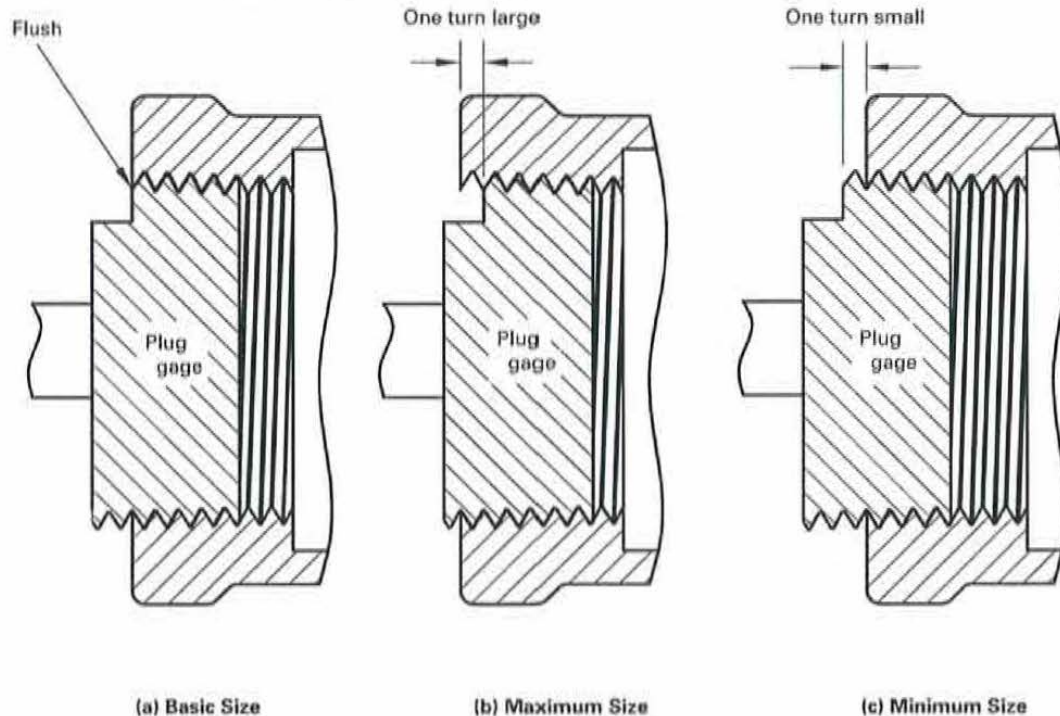

Fig. 6 Gaging Internal Taper Threads With  $L_1$  Plug Gage

sharp edge to better ensure sharp edge removal. The existence of chamfers has the effect of reducing engaged thread length, and larger chamfers further reduce thread length. Designers and manufacturers are therefore cautioned to take into consideration the effects of chamfers on the intended assembly. The gaging reference point for a product thread depends on the chamfer diameter.

**3.2.4.1** For an external thread with a chamfer diameter smaller than the minor diameter, the reference point is the last scratch of the chamfer cone [see Fig. 5, illustration (a)].

**3.2.4.2** For an internal thread with a chamfer diameter larger than the major diameter, the reference point is the last scratch of the chamfer cone [see Fig. 5, illustration (b)].

**3.2.4.3** For an external thread with a chamfer diameter equal to or greater than the minor diameter, the reference point is the end of the fitting [or pipe; see Fig. 5, illustration (c)].

**3.2.4.4** For an internal thread with a chamfer diameter equal to or smaller than the major diameter, the reference point is the end of the fitting [see Fig. 5, illustration (d)].

**3.2.4.5** Recesses and counterbores must be accounted for when gaging internal threads. Dogpoints or lead-ins to external threads must be accounted for

when gaging external threads. These features must not be included in thread length measurements.

**3.2.5 Acceptance of Product Made Prior to This Revision.** This revision includes changes to gaging practice, specifically the changing of the gaging point of reference for external threads having chamfer diameters smaller than the minor diameter at the small end. This change is an important advance and should be implemented upon issuance of this Standard. As long as there are no specifically identified assembly issues, products conforming to the prior revision of this document are considered suitable and allowed for sale and acceptance until depleted.

**3.2.6 Coated Threads.** The specifications in this Standard do not include an allowance for coating (or plating). If coating is desired, it may be necessary to modify the threads since the gaging requirements must be satisfied for coated and uncoated parts. This may be emphasized by adding the words "AFTER COATING" to the thread designation of the finished product. Gage limits before coating may be specified, followed by the words "BEFORE COATING" or "PRE-PLATE."

**3.2.6.1 Coating Buildup.** If significant, a coating buildup will necessitate making external threads smaller and internal threads larger, so that after coating, thread sizes and gaging are conforming to the Standard. It is important to note that coating buildup on the flanks of



threads increases external thread pitch diameter sizes and reduces internal pitch diameter sizes by four times the coating thickness. Coating buildup in crests and roots increases major diameter sizes and decreases minor diameter sizes by two times the coating thickness. See paras. 3.2.6.2 and 3.2.6.3 for guidance on compensating for uniform coatings. Many product coatings do not coat features evenly. Information about coating buildup should be obtained from the coating processor.

**3.2.6.2 Precoating Gaging Standoff Compensation, Internal Thread.** Thread gaging standoff tolerance may be adjusted to compensate for a uniform coating with an upper and lower thickness tolerance in the following manner:

EXAMPLE:  $\frac{1}{2}$ -14 NPT internal thread with uniform coating thickness of 0.0002 in. to 0.0004 in. After coating, final product tolerance is flush  $\pm 1$  turn standoff. Before coating, tolerance is established by the following formula:

Large end of product tolerance:  
 $1 \text{ turn large} + (\text{minimum coating thickness} \times 60\text{-deg thread constant} \times \text{taper standoff constant})$   
 or  
 $0.0714 \text{ in. large} + (0.0002 \text{ in.} \times 4 \times 16) = 0.0842 \text{ in. large}$

Small end of product tolerance:  
 $1 \text{ turn small} - (\text{maximum coating thickness} \times 60\text{-deg thread constant} \times \text{taper standoff constant})$   
 or  
 $0.0714 \text{ in. small} - (0.0004 \text{ in.} \times 4 \times 16) = 0.0458 \text{ in. small}$

Calculated before coating standoff tolerance: 0.0842 in. large to 0.0458 in. small.

Threads with nonuniform coatings or other residual effects (like nicks) may have to be compensated for differently to obtain standard after-coating tolerances.

**3.2.6.3 Precoating Gaging Standoff Compensation, External Thread.** Thread gaging standoff tolerance may be adjusted to compensate for a uniform coating with an upper and lower thickness tolerance in the following manner:

EXAMPLE:  $\frac{1}{2}$ -14 NPT external thread with uniform coating thickness of 0.0002 in. to 0.0004 in. After coating, final product tolerance is flush  $\pm 1$  turn standoff. Before coating, tolerance is established by the following formula:

Small end of tolerance:  
 $1 \text{ turn small} + (\text{minimum coating thickness} \times 60\text{-deg thread constant} \times \text{taper standoff constant})$   
 or  
 $0.0714 \text{ in. small} + (0.0002 \text{ in.} \times 4 \times 16) = 0.0842 \text{ in. small}$

Large end of tolerance:  
 $1 \text{ turn large} - (\text{maximum coating thickness} \times 60\text{-deg thread constant} \times \text{taper standoff constant})$   
 or  
 $0.0714 \text{ in. large} - (0.0004 \text{ in.} \times 4 \times 16) = 0.0458 \text{ in. large}$

Calculated before coating standoff tolerance: 0.0842 in. small to 0.0458 in. large.

Threads with nonuniform coatings or other residual effects (like nicks) may have to be compensated for differently to obtain standard after-coating tolerances.

**3.2.6.4 Precoating Gages.** Special modified ring and plug gages may be designed and used in place of the standoff compensation methods described above. These are based on the standard gages described in section 7. It is common to modify the gage diameters such that the plug's basic step and the small end of the ring are flush with product threads that are at a compensated basic size. Formulas similar to those above may be used in arriving at modified gage sizes.

**3.2.7 Supplemental Gaging** Conformance to this Standard requires that all basic design dimensions be met (within applicable tolerances), including taper, thread truncations, lead, and thread flank angle over the  $L_2$  and  $L_3$  lengths. Since the gaging systems prescribed in this Standard may not ensure conformance to these individual thread elements, supplemental gaging may be employed to evaluate conformance. When supplemental gaging is employed, it shall be agreed upon by the supplier and purchaser. It is common to measure truncation equivalent width of flat (Table 1) by optical projection of external threads directly to determine whether or not such truncations are within the limits specified or particularly to see that maximum truncation is not exceeded.

### 3.3 Acceptability

Thread gages made to this Standard will have variation between them due to gage manufacturing tolerances and allowable gage wear. There can be more variation in tapered thread gaging than straight thread gaging due to the interplay of the taper variations (within tolerance) between gages and products. The functional gaging requirement of this Standard will be met when the product is accepted by a gage that conforms to this Standard. It is acknowledged that the allowable differences in conforming gages may produce wider ranges of product dimensions than would be constructed strictly by the thread drawings and tolerances. However, product functionality and interchangeability are ultimately met using these gages.

## 4 SPECIFICATIONS FOR INTERNAL STRAIGHT THREADS IN PIPE COUPLINGS, NPSC

### 4.1 Pressure-Tight Internal Straight Pipe Threads

Threads made in accordance with these specifications are straight (parallel) threads of the same thread form as the American National Standard Taper Pipe Thread specified in para. 2.1. They are used to form pressure-tight joints when assembled with an NPT external taper thread and made up wrench-tight with sealant (see para. 1.4).



**Table 4 Dimensions, Internal Straight Threads in Pipe Coupling, NPSC  
(Pressure-Tight Joints With Sealant)**

Nominal Pipe Size	O.D. Pipe, <i>D</i>	Threads/Inch, <i>n</i>	Minimum Minor Diameter	Pitch Diameter [Note (1)]	
				Min.	Max.
1	2	3	4	5	6
1/8	0.405	27	0.340	0.3701	0.3771
1/4	0.540	18	0.442	0.4864	0.4968
3/8	0.675	18	0.577	0.6218	0.6322
1/2	0.840	14	0.715	0.7717	0.7851
3/4	1.050	14	0.925	0.9822	0.9956
1	1.315	11 1/2	1.161	1.2305	1.2468
1 1/4	1.660	11 1/2	1.506	1.5752	1.5915
1 1/2	1.900	11 1/2	1.745	1.8142	1.8305
2	2.375	11 1/2	2.219	2.2881	2.3044
2 1/2	2.875	8	2.650	2.7504	2.7739
3	3.500	8	3.277	3.3768	3.4002
3 1/2	4.000	8	3.777	3.8771	3.9005
4	4.500	8	4.275	4.3754	4.3988

## NOTE:

(1) The actual pitch diameter of the straight tapped hole will be slightly smaller than the value given when gaged with a taper plug gage as specified in para. 4.2.1.

**4.1.1 Thread Designation.** The American National Standard Coupling Straight Pipe Threads are designated in accordance with para. 1.3.1 as follows:

$$\frac{1}{8}\text{-}27 \text{ NPSC}$$

**4.1.2 Dimensions and Limits of Size.** The dimensions and pitch diameter limits of size are specified in Table 4. The pitch diameter sizes correspond to the gaging tolerance of one and one-half turns large or small of the NPT  $E_1$ . The major and minor diameters vary with the pitch diameter, as the American National Standard Pipe Thread form is maintained within the truncation tolerances shown in Table 1.

#### 4.2 Gaging NPSC Internal Threads

Internal taper thread gages in accordance with section 7 shall be used to gage NPSC straight internal pipe threads.

**4.2.1  $L_1$  Plug Gage.** The  $L_1$  plug gage and internal product thread are screwed together hand-tight and the position relative to the basic step of the gage is noted. This is the standoff. The NPSC tolerance for the standoff is  $\pm 1\frac{1}{2}$  turns (or  $\pm 1\frac{1}{2}$  pitch, as shown in column 4 of Table 2) from the basic step of the plug gage. See paras. 3.2.4.1 and 3.2.4.2 for chamfered threads.

**4.2.2  $L_1$  Internal Indicating Gage.** When product is engaged in an indicating gage set with a master gage, readings indicate the diametral variation from basic. The tolerance from basic is the diametral equivalent to  $\pm 1\frac{1}{2}$  pitches (or  $\pm 0.0625/n$ , as shown in column 23 of Table 2). See paras. 3.2.4.1 and 3.2.4.2 for chamfered threads.

**CAUTION:** When using tapered thread gages in straight product threads, nonuniformity of gage wear is a particular problem; therefore, tapered gages used for this application should be checked by direct measurement of thread form and size in addition to checking against a master.

## 5 SPECIFICATIONS FOR RAILING JOINT TAPER PIPE THREADS, NPTR

### 5.1 Railing Joints

Railing joints that require a rigid mechanical taper thread joint may be made with external and internal taper threads. The external thread is the same as the NPT thread, except that it is shortened to permit the use of the larger end of the pipe thread. The internal thread has the same basic dimensions as the NPT internal thread; however, a recess in the fitting provides a covering for the last scratch or sharp edges of incomplete threads on the pipe. The dimensions of these threads are shown in Table 5.

**5.1.1 Thread Designation.** American National Standard Railing Joint Taper Pipe Threads are designated in accordance with para. 1.3.1 as follows:

$$\frac{1}{2}\text{-}14 \text{ NPTR}$$

**5.1.2 Form of Thread.** The form of the thread is the same as the American National Standard Taper Pipe Thread shown in Figs. 1 and 2.

### 5.2 Gaging and Tolerances, NPTR

The dimensions of these threads are specified in Table 5. Gaging is performed using standard NPT  $L_1$  gages

**Table 5 Dimensions of External and Internal Taper Pipe Threads for Railing Joints, NPTR (Mechanical joints)**

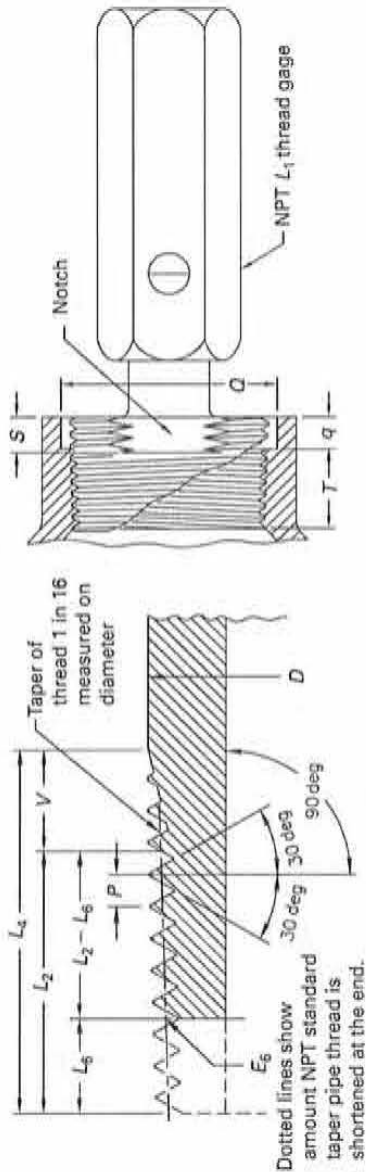

Nominal Pipe Size	O.D. of Pipe, D	n	Threads/Inch,	Height of Thread, h	Pitch Diameter at End of External Thread, E <sub>6</sub>	Shortening of Thread, L <sub>6</sub>		Length of Effective Thread, L <sub>2</sub> - L <sub>6</sub>		Total Length of External Thread, L <sub>4</sub> - L <sub>6</sub>		Maximum Incomplete Chamfer of Dia., V		Minimum Depth of Recess in Fitting, q	Minimum Dia. of Recess in Fitting, Q	Minimum Length, T	Distance Gage <sup>1</sup> Notch Comes Below Face of Fitting, S	
						In.	Threads	In.	Threads	In.	Threads	In.	Threads				In.	Threads
1	2	3	4	0.1000	0.1000	0.261	3	0.463	5.32	0.724	8.33	0.261	3	0.26	1.92	0.43	0.348	4
	2.375	11.5	0.0696	0.0696	2.2853	0.261	3	0.496	5.70	0.757	8.70	0.261	3	0.26	2.40	0.43	0.348	4
	2.875	8	0.1000	0.1000	2.7508	0.500	4	0.638	5.10	1.013	8.10	0.375	3	0.38	2.90	0.63	0.625	5
	3.500	8	0.1000	0.1000	3.3719	0.500	4	0.700	5.60	1.075	8.60	0.375	3	0.38	3.53	0.63	0.625	5
	4.000	8	0.1000	0.1000	3.8688	0.500	4	0.750	6.00	1.125	9.00	0.375	3	0.38	4.04	0.63	0.625	5
	4.500	8	0.1000	0.1000	4.3656	0.500	4	0.800	6.40	1.175	9.40	0.375	3	0.38	4.54	0.63	0.625	5

GENERAL NOTE: These dimensions agree with those developed by the Manufacturers Standardization Society of the Valve and Fittings Industry. Thread lengths are specified to three decimal places for convenience.

NOTE:

(1) American National Standard Taper Pipe Thread Plug Gage (see section 7).



(see section 7). Since the basic length and size (Table 5, column 5) of the external thread have been reduced significantly from standard NPT, the start end of the product thread will always lie inside the face of the gage. The maximum allowable variation in the external thread is no turns large and one turn small from this modified basic.

**EXAMPLE:**

For a  $\frac{1}{2}$ -14 NPTR external thread, Table 5, column 7: the start end of the modified basic thread lies three threads inside the face of the gage. The tolerance during gaging will be 2 turns large to 3 turns large.

For a  $\frac{1}{2}$ -14 NPTR internal thread, Table 5, column 18: the start end of the modified basic thread lies four threads inside the face of the fitting. The tolerance during gaging will be 4 turns large to 5 turns large.

## 6 SPECIFICATIONS FOR STRAIGHT PIPE THREADS FOR MECHANICAL JOINTS; NPSM, NPSL

### 6.1 Straight Pipe Threads for Mechanical Joints

In addition to pressure-tight pipe joints, for which taper external threads and taper or straight internal threads can be used, there are mechanical joints where straight pipe threads are used. Their pitch diameters and root and crest truncations vary as described below. These types of joints are as follows:

- (a) free-fitting mechanical joints for fixtures, Table 6, both external and internal, NPSM
- (b) loose-fitting mechanical joints with lock-nuts, Table 7, both external and internal, NPSL

**6.1.1 Thread Designations.** These threads are designated in accordance with para. 1.3.1 as follows:

$\frac{1}{8}$ -27 NPSM

$\frac{1}{8}$ -27 NPSL

**6.1.2 Pitch and Flank Angle.** The pitch and flank angle are the same as the corresponding dimensions of the taper pipe thread described in section 3.

**6.1.3 Diameter of Thread.** The basic pitch diameter for both the external and internal threads is equal to  $E_1$  of Table 2, which is the same as the large end of the internal NPT thread.

### 6.2 Free-Fitting Mechanical Joints for Fixtures, NPSM

Pipe is often used for special applications where there are no internal pressures and, consequently, no sealing requirements. Also, straight pipe threads are sometimes found more suited or convenient where straight thread joints are required for mechanical assemblies. In these cases, NPSM threads can be used, creating a reasonably close fit of mating parts. The dimensions of these threads are given in Table 6. Gaging is described in para. 6.4.

### 6.3 Loose-Fitting Mechanical Joints With Locknuts, NPSL

The American National Standard External Locknut Thread is designed to produce a pipe thread having the largest diameter that is possible to cut on standard pipe. Ordinarily, straight internal threads are used with these straight external threads, providing a loose fit. The dimensions of these threads are given in Table 7. It will be noted that the maximum major diameter of the external thread is slightly greater than the nominal outside diameter of the pipe. The normal manufacturer's variation in pipe diameter provides for this increase. One application of a taper pipe thread in combination with a locknut thread that has been in use for some time is that shown in Table 7. It consists of the nipple threaded joint used to connect standpipes with the floor or wall of a water supply tank.

### 6.4 Gaging for NPSM and NPSL Threads

Gaging to properly control the production of these straight threads should be through the use of GO and NOT GO gages or indicating type gages.

**6.4.1 GO Gaging.** The GO size is acceptable when the GO thread gage (plug or ring) freely engages the full threaded length of the product.

**6.4.2 NOT GO Gaging.** The NOT GO size is acceptable when the NOT GO thread gage (plug or ring) applied to the product thread does not enter more than three complete turns. The gage should not be forced. Special conditions, such as exceptionally thin or ductile material, small number of threads, etc., may necessitate modification of this practice.

**6.4.3 Indicating Gages.** When using indicating gages for straight threads, refer to ASME B1.2 for use.

**6.4.4 Gage Dimensions.** Gages used for NPSM shall be made to the pitch diameter limits specified in Table 6. Gages used for NPSL shall be made to the pitch diameter limits specified in Table 7. These gages shall be made in accordance with standard practice for straight thread gages as outlined in ASME B1.2. The minimum major diameter of the GO thread plug gage or internal functional indicating gage shall be equal to the minimum pitch diameter of the internal thread plus an amount equal to 0.64951905*P*. The maximum major diameter of the NOT GO thread plug gage shall be equal to the maximum pitch diameter of the internal thread plus an amount equal to 0.43301270*P*. The maximum minor diameter of the GO thread ring gage or external functional diameter indicating gage shall be equal to the maximum pitch diameter of the external thread minus an amount equal to 0.43301300*P*. The minimum minor diameter of the NOT GO thread ring gage shall be equal to the minimum pitch diameter of the external thread minus an amount equal to 0.21650635*P*.



**Table 6 Dimensions of External and Internal Straight Pipe Threads for Fixtures, NPSM (Free-Fitting Mechanical Joints)**

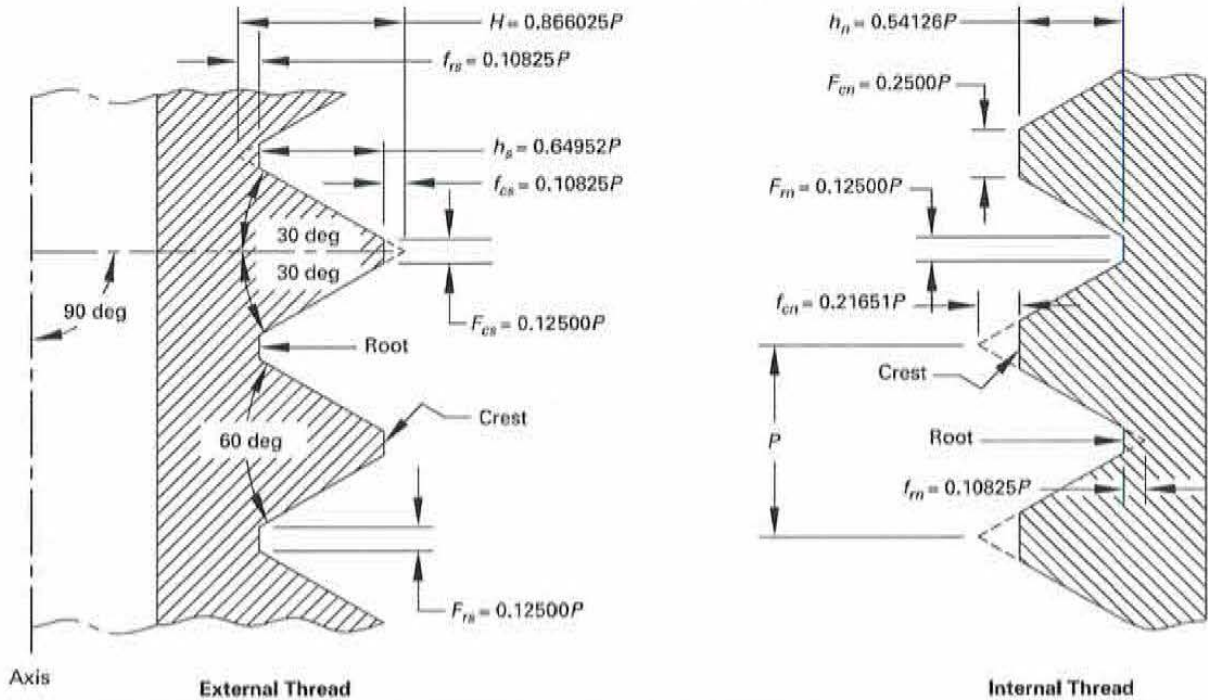

Nominal Pipe Size	O.D. of Pipe, <i>D</i>	Threads/Inch	Allowance	External Thread, Class 2A				Internal Thread, Class 2B			
				Major Diameter		Pitch Diameter		Minor Diameter		Pitch Diameter	
				Max.	Min.	Max.	Min.	Min.	Max.	Min. <sup>1</sup>	Max.
1	2	3	4	5	6	7	8	9	10	11	12
1/8	0.405	27	0.0011	0.397	0.390	0.3725	0.3689	0.358	0.364	0.3736	0.3783
1/4	0.540	18	0.0013	0.526	0.517	0.4903	0.4859	0.468	0.481	0.4916	0.4974
3/8	0.675	18	0.0014	0.662	0.653	0.6256	0.6211	0.603	0.612	0.6270	0.6329
1/2	0.840	14	0.0015	0.823	0.813	0.7769	0.7718	0.747	0.759	0.7784	0.7851
3/4	1.050	14	0.0016	1.034	1.024	0.9873	0.9820	0.958	0.970	0.9889	0.9958
1	1.315	11.5	0.0017	1.293	1.281	1.2369	1.2311	1.201	1.211	1.2386	1.2462
1 1/4	1.660	11.5	0.0018	1.638	1.626	1.5816	1.5756	1.546	1.555	1.5834	1.5912
1 1/2	1.900	11.5	0.0018	1.877	1.865	1.8205	1.8144	1.785	1.794	1.8223	1.8302
2	2.375	11.5	0.0019	2.351	2.339	2.2944	2.2882	2.259	2.268	2.2963	2.3044
2 1/2	2.875	8	0.0022	2.841	2.826	2.7600	2.7526	2.708	2.727	2.7622	2.7720
3	3.500	8	0.0023	3.467	3.452	3.3862	3.3786	3.334	3.353	3.3885	3.3984
3 1/2	4.000	8	0.0023	3.968	3.953	3.8865	3.8788	3.835	3.848	3.8888	3.8988
4	4.500	8	0.0023	4.466	4.451	4.3848	4.3771	4.333	4.346	4.3871	4.3971
5	5.563	8	0.0024	5.528	5.513	5.4469	5.4390	5.395	5.408	5.4493	5.4598
6	6.625	8	0.0024	6.585	6.570	6.5036	6.4955	6.452	6.464	6.5060	6.5165

GENERAL NOTES:

- (a) NPSM threads have a form similar to that of UN threads and tolerances similar to 2A/2B. The internal thread has a minimum pitch diameter equal to  $E_1$  of NPT threads.
- (b) The minor diameters of external threads and major diameters of internal threads are those as produced by commercial straight pipe dies and commercial ground straight pipe taps. The major diameter of the external thread has been calculated on the basis of a truncation of  $0.10825P$ , and the minor diameter of the internal thread has been calculated on the basis of a truncation of  $0.21651P$ , to provide no interference at crest and root when product is gaged.

NOTE:

- (1) Column 11 is the same as the pitch diameter at the large end of internal thread,  $E_1$ , Basic (see Table 2, column 8).

**Table 7 Dimensions, External and Internal Straight Pipe Thread for Locknut Connections, NPSL  
(Loose-Fitting Mechanical Joints)**

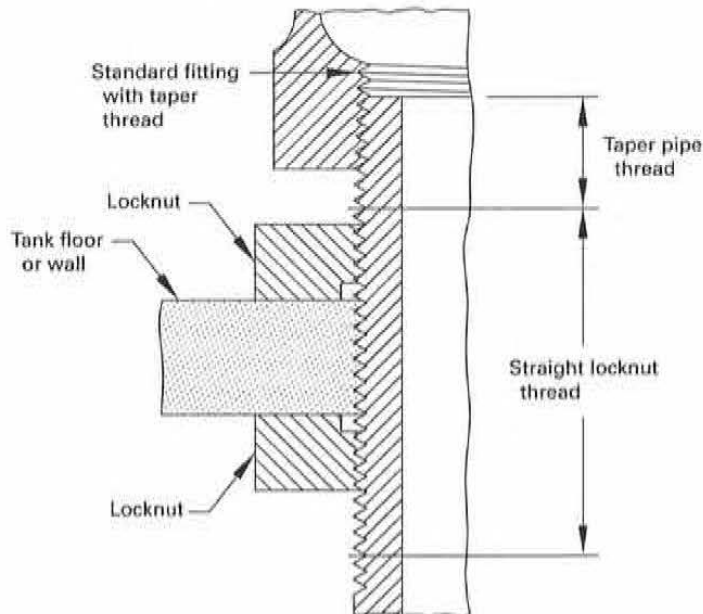

Nominal Pipe Size	O.D. of Pipe, <i>D</i>	Threads/ Inch	External Threads			Internal Threads		
			Maximum <sup>1</sup> Major Diameter	Pitch Diameter		Minimum <sup>1</sup> Minor Diameter	Pitch Diameter	
				Max.	Min.		Min.	Max.
1	2	3	4	5	6	7	8	9
1/8	0.405	27	0.409	0.3840	0.3805	0.362	0.3863	0.3898
1/4	0.540	18	0.541	0.5038	0.4986	0.470	0.5073	0.5125
3/8	0.675	18	0.678	0.6409	0.6357	0.607	0.6444	0.6496
1/2	0.840	14	0.844	0.7963	0.7896	0.753	0.8008	0.8075
3/4	1.050	14	1.054	1.0067	1.0000	0.964	1.0112	1.0179
1	1.315	11.5	1.318	1.2604	1.2523	1.208	1.2658	1.2739
1 1/4	1.660	11.5	1.663	1.6051	1.5970	1.553	1.6106	1.6187
1 1/2	1.900	11.5	1.902	1.8441	1.8360	1.792	1.8495	1.8576
2	2.375	11.5	2.376	2.3180	2.3099	2.265	2.3234	2.3315
2 1/2	2.875	8	2.877	2.7934	2.7817	2.718	2.8012	2.8129
3	3.500	8	3.503	3.4198	3.4081	3.344	3.4276	3.4393
3 1/2	4.000	8	4.003	3.9201	3.9084	3.845	3.9279	3.9396
4	4.500	8	4.502	4.4184	4.4067	4.343	4.4262	4.4379
5	5.563	8	5.564	5.4805	5.4688	5.405	5.4884	5.5001
6	6.625	8	6.620	6.5372	6.5255	6.462	6.5450	6.5567
8	8.625	8	8.615	8.5313	8.5196	8.456	8.5391	8.5508
10	10.750	8	10.735	10.6522	10.6405	10.577	10.6600	10.6717
12	12.750	8	12.732	12.6491	12.6374	12.574	12.6569	12.6686

## NOTE:

- (1) As the American National Standard Straight Pipe Thread form of thread is produced by a single tool, the major and minor diameters of the internal thread and the minor diameter of the external thread are presumed to vary with the pitch diameter. The major diameter of the external thread is usually determined by the diameter of the pipe. These theoretical diameters result from adding the depth of the truncated thread ( $0.666025P$ ) to the maximum pitch diameters in column 5, and it should be understood that commercial pipe will not always have these maximum major diameters. The locknut thread is established on the basis of retaining the greatest possible amount of metal thickness between the bottom of the thread and the inside of the pipe. In order that a locknut may fit loosely on the externally threaded part, an allowance equal to the increase in pitch diameter per turn is provided, with a tolerance of 1.5 turns for both external and internal threads.



## 7 GAGES AND GAGE TOLERANCES FOR AMERICAN NATIONAL STANDARD TAPER PIPE THREADS, NPT

### 7.1 Gage Design

Gages should be made of hardened steel and conform to the designs recommended in ASME B47.1 (see Figs. 7 and 8).

**7.1.1 Gages for External Threads.** The  $L_1$  ring gage and indicating gage elements have a length equal to dimension  $L_1$ .

**7.1.2 Gages for Internal Threads.** The  $L_1$  plug and indicating gage elements have a length equal to dimension  $L_2$ . The  $L_1$  plug gage has a gaging notch located a distance  $L_1$  from the small end. In locating the basic gaging notch, the plane of the notch should intersect the crest of the gage thread. The notched area of the large end of the plug gage shall remain sharp; however, it should not have burrs extending outside the thread form.

**7.1.3 Partial End Threads.** Partial end threads shall be removed on both ends of the ring gage and both ends of the plug gage. This shall be done by chamfering to the minor diameter of plugs and major diameter of rings or "convolution" to full-form profile. This avoids possible seating error from bent or malformed feathered edge and protects the thread from chipping.

**7.1.4 Marking of Gages.** Each gage shall be marked so as to indicate clearly the nominal size of pipe, threads per inch, and the proper thread series designation as given in the respective section of this Standard. For rings, the marking shall be on the face of the large end.

### 7.2 Master Gages

Master gages are used to inspect working gages at the times of manufacture and calibration. They are also used in setting indicating gages. Additionally, master rings inspect master plugs, and master plugs inspect master rings. The  $L_1$  plug and ring master gages are made to the basic dimensions specified in Table 8. The thread roots of these gages shall clear a  $0.0381P$  flat or may be undercut beyond a sharp  $V$ . The crests are truncated by  $0.100P$ .

**7.2.1 Master Gage Tolerances.** Master gages should be made to the basic dimensions as accurately as possible, but in no case shall the cumulative variation exceed one-half of the total cumulative tolerance specified in columns 13 and 14 of Table 9. A master ring and master plug are mated, the large end of the ring seating flush at the plug notch within  $\pm 0.002$  in. for sizes  $\frac{1}{16}$  through 2, within  $\pm 0.003$  in. for sizes  $2\frac{1}{2}$  through 12, and within  $\pm 0.005$  in. for sizes 14 and larger. A supplementary check by optical or other means should be made of flank angle

and form. Each master gage should be accompanied by a record of the measurements of all elements of the thread and the standoff of master plug or master ring (large end of ring gage to basic notch of plug gage).

**CAUTION:** It should be understood that only a specifically matched set of masters ( $L_1$  plug and  $L_1$  ring) can be expected to mate with each other within the tolerance specified above and in General Note (a) of Table 9. There are many characteristics or variations in gage elements that may combine to cause a significant standoff difference between master gages that are not specifically matched.

### 7.3 Working Gages

Working gages are used to inspect product threads. They are made to the basic dimensions given in Table 8. The roots of all gage threads shall clear  $0.0381P$  width. A sharp  $V$  or undercut clearance is acceptable. The crests are to be truncated an amount equal to  $0.140P$  for 27 threads per inch (tpi),  $0.109P$  for 18 tpi, and  $0.100P$  for 14-tpi,  $1\frac{1}{2}$ -tpi, and 8-tpi threads (see Fig. 8). It is to be noted that these gages are truncated at the crest so that they bear only on the flanks of the thread. Thus, they do not check the product crest or root truncations. When it is deemed necessary to determine whether or not such truncations are within the limits specified, or particularly that the maximum truncations are not exceeded, optical projection is one common method.

**7.3.1 Working Gage Tolerances.** Working gages should be made to the basic dimensions specified in Table 8 and within tolerances specified in Table 9. The maximum wear on a working plug gage shall not be more than the equivalent of  $\frac{1}{4}$  turn small from basic, when checked with a master gage. The maximum wear on a working ring gage shall not be more than  $\frac{1}{4}$  turn large from basic, when checked with a master gage. A supplementary check by optical or other means should be made of flank angle and form.

### 7.4 Relation of Lead and Angle Variations to Pitch Diameter Tolerances of Gages

When it is necessary to compute from measurements the decimal part of a turn that a gage varies from the basic dimensions, Tables 10 and 11 should be used. Table 10 gives the correction in diameter for angle variations, and Table 11 gives the correction in diameter for lead variations. These corrections are always added to the pitch diameter in the case of external threads and subtracted in the case of internal threads, regardless of whether the lead or angle variations are either plus or minus. The diameter equivalent for lead and angle variations plus the pitch diameter variation multiplied by 16 gives the longitudinal variation from basic at the gaging notch. This longitudinal variation divided by the pitch equals the decimal part of a turn that the gage varies from basic at the gaging notch.



Fig. 7 NPT Standard Taper Pipe Thread Plug and Ring Gages

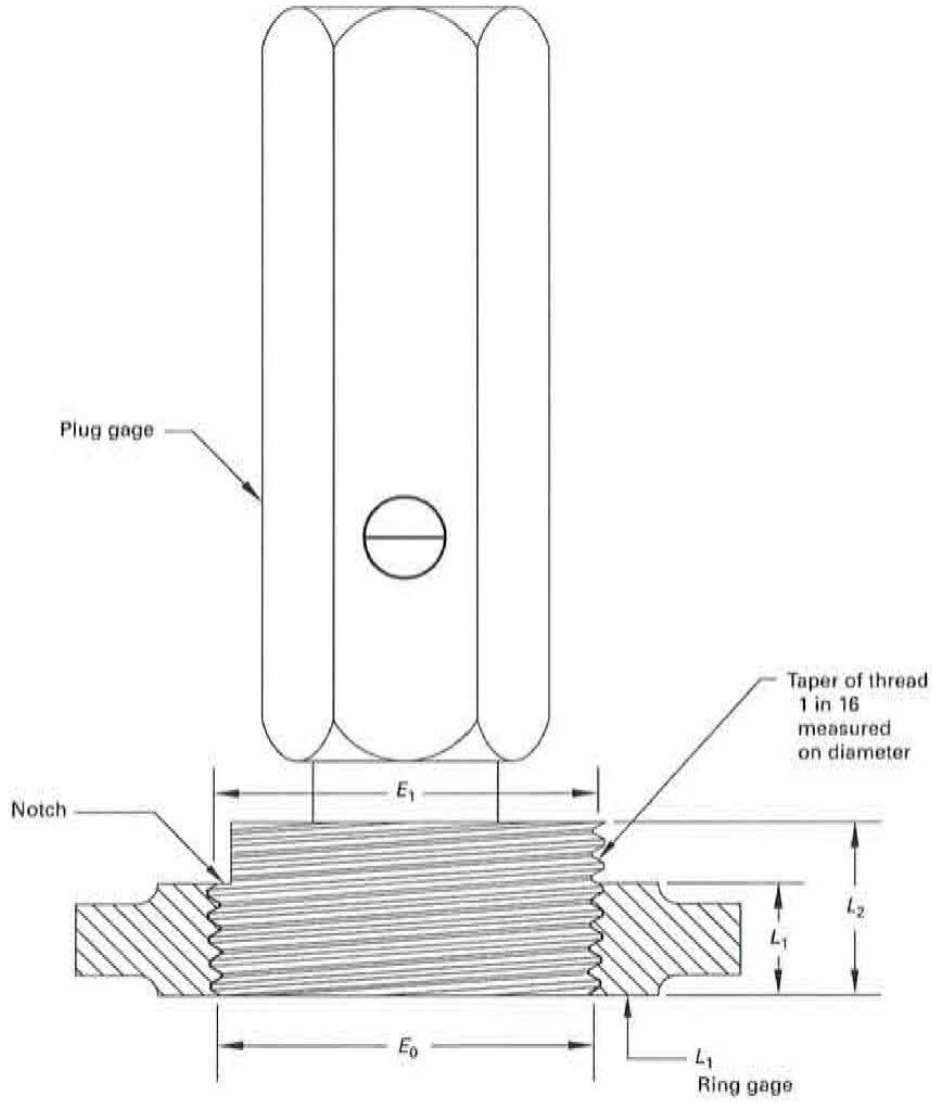
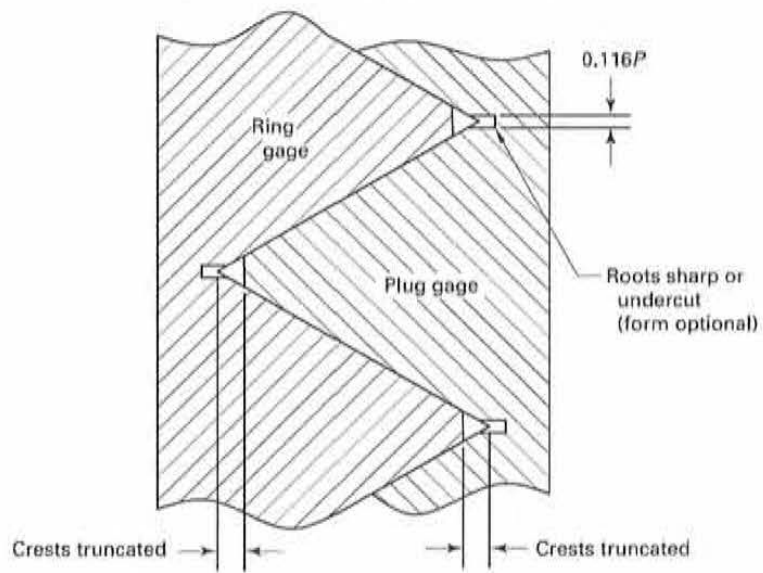

Fig. 8 Suggested Form of Gage Thread



GENERAL NOTE: Roots must clear  $0.0381P$  width.





Table 9 Working Gage Tolerances for American National Standard Taper Pipe Thread, NPT

Nominal Pipe Size	O.D. of Pipe, D	Threads/inch	Tolerance on Pitch Dia., <sup>1</sup>		Tolerance on Lead <sup>2,3</sup>		Tolerance on Half Angle, <sup>4</sup> Minutes		Tolerance on Taper, <sup>3,5</sup>		Tolerance on Major Dia.,		Tolerance on Minor Dia.,		Total Cumulative Tolerances on Pitch Dia.		Standoff Between Plug and Ring Gages at Gaging Notch for Dimensions at Opposite Extreme Tolerance Limits <sup>6</sup>
			±	±	Plugs	Rings	Plugs	Rings	±	±	Plugs	Rings	Plugs	Rings	Plugs	Rings	
1	2	3	4	5	6	7	8	9	10	11	12	13	14	15			
1/16	0.3125	27	0.0002	0.0002	0.0003	15	20	0.0003	0.0006	0.0004	0.0004	0.00080	0.00118	0.032			
1/8	0.405	27	0.0002	0.0002	0.0003	15	20	0.0003	0.0006	0.0004	0.0004	0.00080	0.00118	0.032			
3/16	0.540	18	0.0002	0.0002	0.0003	15	20	0.0004	0.0007	0.0006	0.0006	0.00092	0.00134	0.036			
1/4	0.675	18	0.0002	0.0002	0.0003	15	20	0.0004	0.0007	0.0006	0.0006	0.00092	0.00134	0.036			
5/16	0.840	14	0.0003	0.0002	0.0003	10	15	0.0006	0.0009	0.0010	0.0010	0.00097	0.00142	0.038			
3/8	1.050	14	0.0003	0.0002	0.0003	10	15	0.0006	0.0009	0.0010	0.0010	0.00097	0.00142	0.038			
1	1.315	11.5	0.0003	0.0003	0.0004	10	15	0.0008	0.0012	0.0010	0.0010	0.00121	0.00170	0.047			
1 1/4	1.660	11.5	0.0003	0.0003	0.0004	10	15	0.0008	0.0012	0.0010	0.0010	0.00121	0.00170	0.047			
1 1/2	1.900	11.5	0.0003	0.0003	0.0004	10	15	0.0008	0.0012	0.0010	0.0010	0.00121	0.00170	0.047			
2	2.375	11.5	0.0003	0.0003	0.0004	10	15	0.0008	0.0012	0.0010	0.0010	0.00121	0.00170	0.047			
2 1/2	2.875	8	0.0005	0.0004	0.0005	7	10	0.0010	0.0014	0.0016	0.0016	0.00158	0.00211	0.059			
3	3.500	8	0.0005	0.0004	0.0005	7	10	0.0010	0.0014	0.0016	0.0016	0.00158	0.00211	0.059			
3 1/2	4.000	8	0.0005	0.0004	0.0005	7	10	0.0010	0.0014	0.0016	0.0016	0.00158	0.00211	0.059			
4	4.500	8	0.0005	0.0004	0.0005	7	10	0.0010	0.0014	0.0016	0.0016	0.00158	0.00211	0.059			
5	5.563	8	0.0005	0.0004	0.0005	7	10	0.0010	0.0014	0.0016	0.0016	0.00158	0.00211	0.059			
6	6.625	8	0.0005	0.0004	0.0005	7	10	0.0010	0.0014	0.0016	0.0016	0.00158	0.00211	0.059			
8	8.625	8	0.0005	0.0004	0.0005	7	10	0.0010	0.0014	0.0020	0.0020	0.00158	0.00211	0.059			
10	10.750	8	0.0005	0.0004	0.0005	7	10	0.0010	0.0014	0.0020	0.0020	0.00158	0.00211	0.059			
12	12.750	8	0.0005	0.0004	0.0005	7	10	0.0010	0.0014	0.0020	0.0020	0.00158	0.00211	0.059			
14 O.D.	14.000	8	0.0008	0.0005	0.0006	7	10	0.0010	0.0014	0.0030	0.0030	0.00206	0.00271	0.076			
16 O.D.	16.000	8	0.0008	0.0005	0.0006	7	10	0.0010	0.0014	0.0030	0.0030	0.00206	0.00271	0.076			
18 O.D.	18.000	8	0.0008	0.0005	0.0006	7	10	0.0010	0.0014	0.0030	0.0030	0.00206	0.00271	0.076			
20 O.D.	20.000	8	0.0008	0.0005	0.0006	7	10	0.0010	0.0014	0.0030	0.0030	0.00206	0.00271	0.076			
24 O.D.	24.000	8	0.0008	0.0005	0.0006	7	10	0.0010	0.0014	0.0030	0.0030	0.00206	0.00271	0.076			

Table 9 Working Gage Tolerances for American National Standard Taper Pipe Thread, NPT (Cont'd)

## GENERAL NOTES:

- (a) The large end of the master ring gage shall be flush with the gaging notch of its master plug when assembled handtight within  $\pm 0.002$  for sizes  $\frac{1}{16}$  to 2, inclusive, within  $\pm 0.003$  for sizes  $2\frac{1}{2}$  to 12, inclusive, and within  $\pm 0.005$  for sizes 14 and larger.
- (b) The tolerances for the length  $L_1$  from small end to gaging notch of the plug gage (Fig. 4) shall be  $+0.000$  and  $-0.001$  for sizes  $\frac{1}{16}$  to 2, inclusive, and  $+0.000$  and  $-0.002$  for sizes  $2\frac{1}{2}$  and larger.
- (c) The tolerances for the overall thread length  $L_2$  of the plug gage (Fig. 4) shall be  $+0.050$  and  $-0.000$  for all sizes.
- (d) Tolerances for the thickness  $L_3$  of the ring gage (Fig. 4) shall be  $-0.000$  and  $+0.001$  for sizes  $\frac{1}{16}$  to 2, inclusive, and  $-0.000$  and  $+0.002$  for sizes  $2\frac{1}{2}$  and larger.

## NOTES:

- (1) To be measured at the gaging notch of plug gage.
- (2) Allowable variation in lead between any two threads in  $L_1$  length of gage (Fig. 4).
- (3) The lead and taper on plug and ring gages shall be measured along the pitch line omitting the imperfect threads at each end.
- (4) In solving for the correction in diameter for angle deviations, the average deviation in half angle for the two sides of thread, regardless of their signs, should be taken.
- (5) Allowable variation in taper in  $L_1$  length of gage (Fig. 4).
- (6) Maximum possible interchange standoff, any ring against any plug other than its master plug, may occur when taper deviations are zero and all other dimensions are at opposite extreme tolerance limits. Average standoff should be well within these maximum limits.

**Table 10 Diameter Equivalent of Variation in Half Included Angle of Thread for Tools and Gages**

Variation <sup>1</sup> in Half Angle (in Minutes)	8 Threads/Inch	11.5 Threads/Inch	14 Threads/Inch	18 Threads/Inch	27 Threads/Inch
1	2	3	4	5	6
1	0.0000559	0.0000389	0.0000320	0.0000249	0.0000166
2	0.0001119	0.0000778	0.0000639	0.0000497	0.0000331
3	0.0001678	0.0001167	0.0000959	0.0000746	0.0000497
4	0.0002237	0.0001556	0.0001278	0.0000994	0.0000663
5	0.0002796	0.0001945	0.0001598	0.0001243	0.0000829
6	0.0003356	0.0002334	0.0001917	0.0001491	0.0000994
7	0.0003915	0.0002723	0.0002237	0.0001740	0.0001160
8	0.0004474	0.0003112	0.0002557	0.0001989	0.0001326
9	0.0005033	0.0003502	0.0002876	0.0002237	0.0001491
10	0.0005593	0.0003891	0.0003196	0.0002486	0.0001657
11	0.0006152	0.0004280	0.0003515	0.0002734	0.0001823
12	0.0006711	0.0004669	0.0003835	0.0002983	0.0001989
13	0.0007271	0.0005058	0.0004155	0.0003231	0.0002154
14	0.0007830	0.0005447	0.0004474	0.0003480	0.0002320
15	0.0008389	0.0005836	0.0004794	0.0003729	0.0002486
16	0.0008948	0.0006225	0.0005113	0.0003977	0.0002651
17	0.0009508	0.0006614	0.0005433	0.0004226	0.0002817
18	0.0010067	0.0007003	0.0005753	0.0004474	0.0002983
19	0.0010626	0.0007392	0.0006072	0.0004723	0.0003149
20	0.0011186	0.0007781	0.0006392	0.0004971	0.0003314
21	0.0011745	0.0008170	0.0006711	0.0005220	0.0003480
22	0.0012304	0.0008559	0.0007031	0.0005469	0.0003646
23	0.0012863	0.0008949	0.0007351	0.0005717	0.0003811
24	0.0013423	0.0009338	0.0007670	0.0005966	0.0003977
25	0.0013982	0.0009727	0.0007990	0.0006214	0.0004143
26	0.0014541	0.0010116	0.0008309	0.0006463	0.0004309
27	0.0015101	0.0010505	0.0008629	0.0006711	0.0004474
28	0.0015660	0.0010894	0.0008949	0.0006960	0.0004640
29	0.0016219	0.0011283	0.0009268	0.0007209	0.0004806
30	0.0016779	0.0011672	0.0009588	0.0007457	0.0004971
45	0.0025169	0.0017509	0.0014382	0.0011186	0.0007457
50	0.0027966	0.0019454	0.0015980	0.0012429	0.0008286

## GENERAL NOTES:

- (a) Values given in inches at 68°F.  
 (b) In solving for the diameter equivalent of angle variations, the average variation in half included angle for the two sides of the thread, regardless of their signs, should be taken.  
 (c) Table is based upon an NPT gage with 0.100P root/crest truncations with equal half-angle variations. For other gages with equal truncations, multiply by

$$\frac{0.86600P - 2 (\text{truncation})}{0.66666667P}$$

## NOTE:

- (1) Diameter equivalent =  $1.53811978P \tan \delta\alpha$ , where  $\delta\alpha$  = variation in half included angle of thread expressed in minutes.



Table 11 Diameter Equivalent of Variation in Lead for Tools and Gages

Variation, $\delta P$	1	2	3	4	5	6	7	8	9	10	11
0.00000	0.00000	0.00000	0.00001	0.00002	0.00003	0.00004	0.00005	0.00006	0.00007	0.00008	0.00009
0.00000	0.00000	0.00000	0.000173	0.0000346	0.0000520	0.0000693	0.0000866	0.0001039	0.0001212	0.0001386	0.0001559
0.00010	0.0001732	0.0001905	0.0002078	0.0002252	0.0002425	0.0002598	0.0002771	0.0002944	0.0003118	0.0003291	0.0003464
0.00020	0.0003464	0.0003637	0.0003810	0.0003984	0.0004157	0.0004330	0.0004503	0.0004676	0.0004850	0.0005023	0.0005196
0.00030	0.0005196	0.0005369	0.0005542	0.0005716	0.0005889	0.0006062	0.0006235	0.0006408	0.0006582	0.0006755	0.0006928
0.00040	0.0006928	0.0007101	0.0007274	0.0007448	0.0007621	0.0007794	0.0007967	0.0008140	0.0008314	0.0008487	0.0008660
0.00050	0.0008660	0.0008833	0.0009006	0.0009180	0.0009353	0.0009526	0.0009699	0.0009872	0.0010046	0.0010219	0.0010392
0.00060	0.0010392	0.0010565	0.0010738	0.0010912	0.0011085	0.0011258	0.0011431	0.0011604	0.0011778	0.0011951	0.0012124
0.00070	0.0012124	0.0012297	0.0012470	0.0012644	0.0012817	0.0012990	0.0013163	0.0013336	0.0013510	0.0013683	0.0013856
0.00080	0.0013856	0.0014029	0.0014202	0.0014376	0.0014549	0.0014722	0.0014895	0.0015068	0.0015242	0.0015415	0.0015588
0.00090	0.0015588	0.0015761	0.0015934	0.0016108	0.0016281	0.0016454	0.0016627	0.0016800	0.0016974	0.0017147	0.0017320
0.00100	0.0017320	0.0017493	0.0017666	0.0017840	0.0018013	0.0018186	0.0018359	0.0018532	0.0018706	0.0018879	0.0019052
0.00110	0.0019052	0.0019225	0.0019398	0.0019572	0.0019745	0.0019918	0.0020091	0.0020264	0.0020438	0.0020611	0.0020784
0.00120	0.0020784	0.0020957	0.0021130	0.0021304	0.0021477	0.0021650	0.0021823	0.0021996	0.0022170	0.0022343	0.0022516
0.00130	0.0022516	0.0022689	0.0022862	0.0023036	0.0023209	0.0023382	0.0023555	0.0023728	0.0023902	0.0024075	0.0024248
0.00140	0.0024248	0.0024421	0.0024594	0.0024768	0.0024941	0.0025114	0.0025287	0.0025460	0.0025634	0.0025807	0.0025980
0.00150	0.0025980	0.0026153	0.0026326	0.0026500	0.0026673	0.0026846	0.0027019	0.0027192	0.0027366	0.0027539	0.0027712
0.00160	0.0027712	0.0027885	0.0028058	0.0028232	0.0028405	0.0028578	0.0028751	0.0028924	0.0029098	0.0029271	0.0029444
0.00170	0.0029444	0.0029617	0.0029790	0.0029964	0.0030137	0.0030310	0.0030483	0.0030656	0.0030830	0.0031003	0.0031176
0.00180	0.0031176	0.0031349	0.0031522	0.0031696	0.0031869	0.0032042	0.0032215	0.0032388	0.0032562	0.0032735	0.0032908
0.00190	0.0032908	0.0033081	0.0033254	0.0033428	0.0033601	0.0033774	0.0033947	0.0034120	0.0034294	0.0034467	0.0034640
0.00200	0.0034640	0.0034813	0.0034986	0.0035160	0.0035333	0.0035506	0.0035679	0.0035852	0.0036026	0.0036200	0.0036373

GENERAL NOTES:

- (a) Values given in inches at 68°F.
- (b) Diameter equivalent =  $1.73205081 \delta P$ , where  $\delta P$  = variation in lead between any two threads.

# NONMANDATORY APPENDIX A

## THE TURNS OF ENGAGEMENT METHOD OF GAGING PRODUCT THREADS

### A-1 METHOD OF GAGING

The turns of engagement method of gaging taper threads determines that there is an adequate number of threads available at hand engagement. This method eliminates the effects of product chamfers during gaging. However, differences between gages' end thread removal and gage crest truncations may give different gaging results for the same product thread. This may necessitate collaboration between supplier and user.

### A-2 TOLERANCE

The theoretical basic turns of engagement are found in column 7 of Table 2. For the turns of engagement method, the turns to remove the  $L_1$  gage from the product thread are counted and must be within the tolerance of basic number of turns,  $\pm 1$  turn.



## NONMANDATORY APPENDIX B TAP DRILL SIZES

Holes prepared for tapping can be either straight or tapered. Both are acceptable as long as the product standards for thread dimensions are met after tapping. The minor diameter of the product threads should be cut by the tap minor diameter to ensure concentricity with the pitch diameter, as well as to generate the proper thread height and truncations. The actual hole size prior to tapping is dependent on many variables and should approximate the diameter  $K_0$ , column 24 of Table 2 (Basic Minor Diameter at Small End of Pipe). Hole sizes may vary from  $K_0$  so the tap can cut an acceptable pipe thread with the required thread height.

## NONMANDATORY APPENDIX C THREAD TYPES AND CORRESPONDING GAGES AND GAGING

See Table C-1.

**Table C-1 Thread Types and Corresponding Gages and Gaging**

Thread to Be Gaged	Type of Thread	Thread		Gaged With	Product Thread Tolerance Applied to Basic Size			
		Internal	External		External		Internal	
					Small	Large	Large	Small
NPT	Pressure	Taper	Taper	$L_1$ or indicating gages	1 Turn	1 Turn	1 Turn	1 Turn
NPSC	Pressure	Straight	...	$L_1$ or indicating gages	...	...	1½ Turns	1½ Turns
NPTR	Mechanical	Taper	Taper	$L_1$ or indicating gages	1 Turn [Note (1)]	0 Turns [Note (1)]	1 Turn [Note (2)]	0 Turns [Note (2)]
NPSM	Mechanical	Straight	Straight	GO/NOT GO or indicating gages	...	...	...	...
NPSL	Mechanical	Straight	Straight	GO/NOT GO or indicating gages	...	...	...	...

**NOTES:**

- (1) See Table 5, column 7 for the modified external thread basic position.
- (2) See Table 5, column 18 for the internal thread basic position below the face of the fitting.

INTENTIONALLY LEFT BLANK



INTENTIONALLY LEFT BLANK

# ASME B1.20.1-2013

ISBN 978-0-7918-6886-7



9 780791 868867



N10313